

Operating Instructions

High Performance Ultraviolet Transilluminators

IMPORTANT: Please read these instructions before operating your UVP Transilluminator to familiarize yourself with its operation.

1.0 Introduction

The UVP High Performance Transilluminators offer the researcher uniform and intense sources of ultraviolet light (radiation). The special design emits high intensity excitation ultraviolet for back-illumination of transparent fluorescent materials. Midrange ultraviolet (302nm) provides a highly sensitive method to detect double-stranded nucleic acids that are labeled with fluorescent dyes such as ethidium bromide or acridine orange. Single stranded nucleic acids may be detected, but with a lower excitation wavelength more sensitive for nucleic acid visualization than the 365nm model.

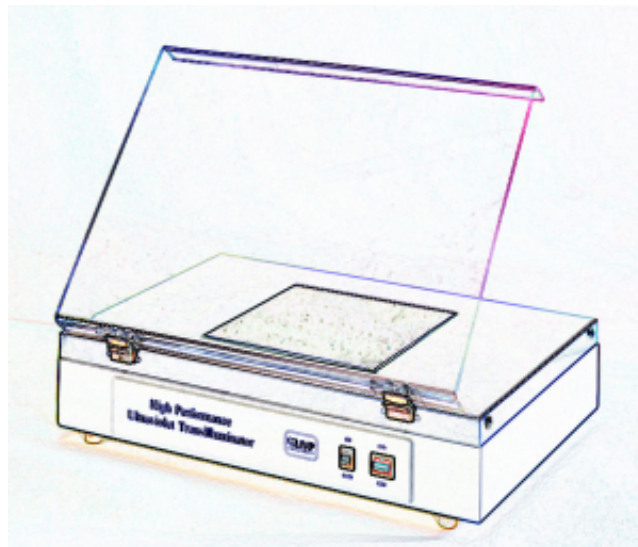

Note: Though UVP refers to the midrange UV waveband as 302nm, others refer to this region as 300nm or 312nm. The spectral output of all these regions is the same.

2.0 Important Safety Information

A word of caution: All UVP High Performance Transilluminators are powerful sources of UV radiation that will cause damage to unprotected eyes and skin. Before operating any unit, be sure all personnel in the area are properly protected. Personnel should protect skin and eyes by wearing ultraviolet protection eyewear, gloves and clothing when operating UV equipment.

It is recommended the transilluminator be installed and operated in a darkroom where access and exposure to UV is limited while the unit is in operation. If a darkroom is unavailable, UVP offers a wide selection of darkrooms or shroud which provide protection from accidental exposure. For product information, contact UVP.

Each transilluminator is shipped with an ultraviolet blocking cover. Even though this cover blocks the UV radiation emitted by the unit, UV Blocking Eyewear should be worn as well. UVP has a complete line of UV Blocking Eyewear: Spectacles, Goggles and Faceshield designed for this purpose. For part numbers, refer to page number 4

3.0 Description/Specifications

The dimensions of the High Performance UV Transilluminators are:



High Performance UV Transilluminator specifications:

Model	Part Number	Wave-length	Volt/Hz/Amp	Filter Size	# of Tubes	Intensity Style
TFM-20	95-0286-01	302nm	115V/60Hz/2.0	20 x 20 cm	4 x 25W	High/Low
TFM-20	95-0286-02	302nm	230V/50Hz/2.0	20 x 20 cm	4 x 25W	High/Low
TFM-20	95-0286-03	302nm	100V/50-60Hz/2.0	20 x 20 cm	4 x 25W	High/Low
TFM-26	95-0285-01	302nm	115V/60Hz/2.0	21 x 26 cm	4 x 25W	High/Low
TFM-26	95-0285-02	302nm	230V/50Hz/2.0	21 x 26 cm	4 x 25W	High/Low
TFM-26	95-0285-03	302nm	100V/50-60Hz/2.0	21 x 26 cm	4 x 25W	High/Low
TFM-30	95-0302-01	302nm	115V/60Hz/2.0	25 x 30 cm	4 x 25W	High/Low
TFM-30	95-0302-02	302nm	230V/50Hz/2.0	25 x 30 cm	4 x 25W	High/Low
TFM-30	95-0302-03	302nm	100V/50-60Hz/2.0	25 x 30 cm	4 x 25W	High/Low
TFM-40	95-0283-04	302nm	115V/60Hz/2.0	20 x 40 cm	4 x 25W	High/Low
TFM-40	95-0283-05	302nm	230V/50Hz/2.0	20 x 40 cm	4 x 25W	High/Low
TFM-40	95-0283-06	302nm	100V/50-60Hz/2.0	20 x 40 cm	4 x 25W	High/Low
TFL-40	95-0283-01	365nm	115V/60Hz/2.0	20 x 40 cm	4 x 25W	High/Low
TFL-40	95-0283-02	365nm	230V/50Hz/2.0	20 x 40 cm	4 x 25W	High/Low
TFL-40	95-0283-03	365nm	100V/50-60Hz/2.0	20 x 40 cm	4 x 25W	High/Low

Width: 19.13” (486mm)

Depth: 13.25” (336mm)

Height: 5.63” (143mm) Height includes cover

4.0 Operation

- Place the transilluminator on a level work surface. Be sure that an air space exists around the bottom of the unit and the work surface. This space allows for the proper air circulation through the unit.
- Plug the female end of the power cord into the transilluminator. For 230V models, or those requiring special power cord connectors, ensure that the proper configuration of male connector or plug has been properly connected to the power cord.
- Plug the male end of the power cord into a properly grounded electrical outlet. The proper voltage of the transilluminator is found on the product information label.
- The transilluminator comes equipped with a UV Blocking Cover which can be adjusted to various angles to suit the researcher’s needs. If this cover is not in place or has been removed, do not operate the unit without securing the cover. If the cover is missing, a UV Blocking Faceshield must be worn to avoid UV exposure to the skin. UV Blocking Eyewear should be worn even with the cover in place to avoid accidental UV exposure. The cover is reversible and can open away from the researcher by removing the four screws (two on both ends of the transilluminator) and rotating the transilluminator top 180°.
- Place gel/sample on the filter area. Gels may be placed on a UVP Gel-Tray (see Section 9 for part numbers) which protects the filter surface from cuts and scratches. It is recommended that gloves be worn to avoid contact with gel and staining agents.
- Position the Dual Intensity Switch to the High operation position.
- Press the ON/OFF switch to ON. The UV tubes within the unit should be glowing beneath the filter after a momentary flickering during the start-up period.
- To lower the UV intensity for extended viewing or sample work, simply press the Dual Intensity Switch to low. A drop in the intensity will now occur. The fluorescence of the stained sample at this time should diminish. As UV radiation is not visible to the eye, the UV transmitting filter does not allow the passage of light up to 400nm (blue). A slightly dimming of this blue color is visible at this time. A UV measuring device with the proper UV wavelength sensor can be used to provide actual intensity reading (see Section 9 for Radiometer information).

9. After viewing/photographing the sample, turn the unit off.
10. Clean the surface with a damp soft cloth or sponge. Never use abrasive cleaners (can damage the UV filter surface).

5.0 Maintenance, Repair and Technical Assistance

UVP offers technical support for all of its products. If you have any questions about the product's use, operation or repair, please call or fax UVP Customer Service in the US at (800)452-6788 or (909)946-3197, Fax: (909)946-3597; In Europe/UK: +44(0)1223-420022; Fax: +44(0)1223-420561.

Note: A Returned Goods Authorization (RGA) number must be obtained from UVP Customer Service before returning any product.

6.0 Changing the Replacement Tubes

1. Disconnect the transilluminator from the electrical supply.
2. A Phillips head screwdriver is required to remove the filter cover.
3. Carefully twist the UV tubes from their sockets.
4. Fit with the proper replacement tubes (refer to Section 9 for ordering information).

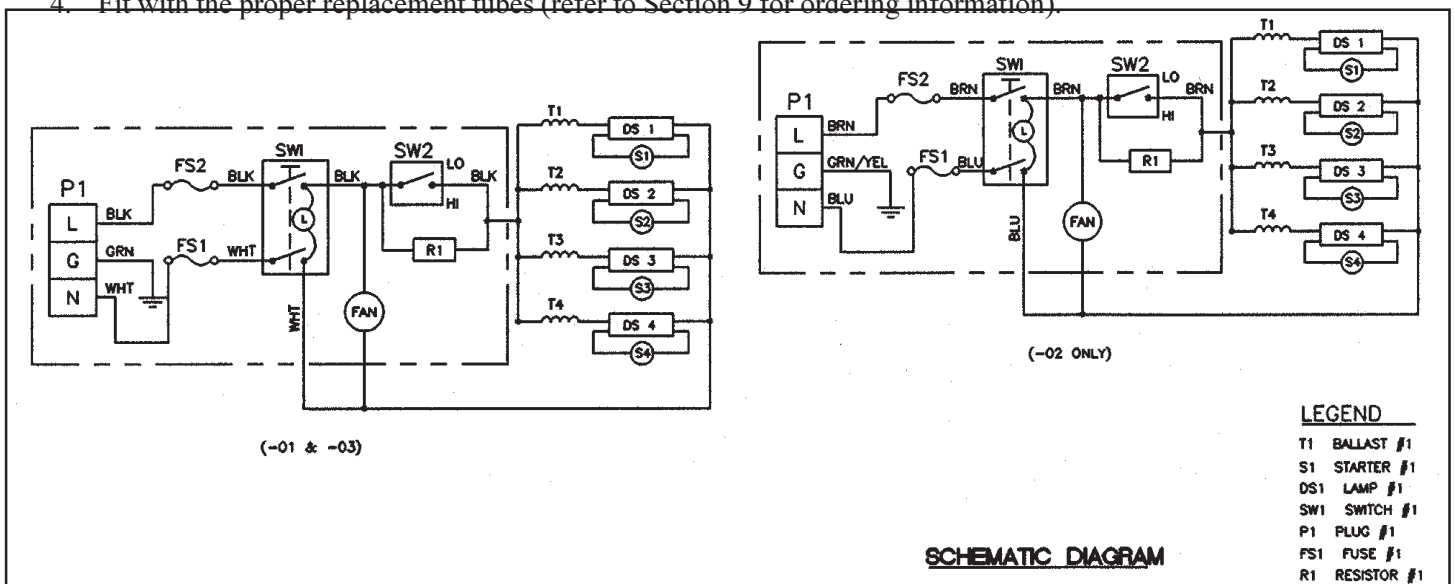

7.0 Cleaning the Transilluminator

The painted surfaces and filter areas of the transilluminator should be cleaned with water, soap, and a sponge or cloth towel. Never use abrasive cleaners, solvent-based cleaners or scouring pads. Always disconnect the transilluminator from the electrical power prior to cleaning.

8.0 Warranty

UVP, Inc. warrants its ultraviolet transilluminators to be free of defects in material and workmanship for a period of two (2) years from the date of purchase. The foregoing warranty of UVP shall be of no force and effect if buyer has

modified or damaged the product. Tubes and filters are warranted for 90 days.

All warranties or merchantability and fitness for any purpose and all other warranties, expressed or implied, except those expressly set forth herein, are deemed waived and excluded.

UVP's duty under the warranty is limited to replacement and/or repair of the defective part at the option of UVP, Inc. UVP shall not be liable for any expenses or damages incurred by the purchaser except as expressly set forth herein, and in no event shall UVP be liable for any special, incidental or consequential damages of any kind. This warranty does not supersede any statutory rights that may be available in certain countries.

9.0 Replacement Parts and Accessories

For replacement parts or components not shown here, call UVP Customer Service or place of purchase. Please have the transilluminator model number available when you call.

Replacement Parts

Part Number	Description
34-0060-01	Tube, 25 watt, 365nm longwave
34-0072-01	Tube, 25 watt, 302nm midrange
38-0189-10	Filter, Assembly for TFL-40 models
38-0189-02	Filter, Assembly for TFM-20 models
38-0189-09	Filter, Assembly for TFM-26 models
38-0189-04	Filter, Assembly for TFM-40 models
42-0054-01	Ballast, 115V models
42-0054-02	Ballast, 230V models
42-0054-03	Ballast, 100V models
56-0002-05	Fuse, 3.2 AMP, Slo-Blo

Accessories

Part Number	Description
85-0002-01	Gel-Cutter
85-0006-01	Gel-Scooper
85-0005-01	Gel-Tray, UV Transmitting, Large
85-0003-01	Gel-Ruler, UV Fluorescing
98-0002-01	Spectacles, UV Blocking
98-0002-02	Goggles, UV Blocking
98-0002-04	Faceshield, UV Blocking
97-0015-02	UVX Radiometer
97-0016-04	UVX-31 Sensor, 302nm
97-0016-02	UVX-35 Sensor, 365nm

Note: The UV transmitting Gel-Tray protects the transilluminator filter glass from scratches.

10.0 UVP ... Providing Quality Products for the Researcher Since 1932

From its start in 1932, UVP has become a story of growth and value fulfillment. Today, UVP services the needs of science, industry and education throughout the world. A special significance of UVP research and development arises from our constant communication with customers. UVP continually invites your comments toward the improvement of UVP products or development of custom types of ultraviolet light sources. UVP will work with you through development and production of a product that meets your specific needs. From all of us at UVP, Thank You.

On-going product developments are posted to UVP's Internet site. Refer to the site regularly for up-to-date information. UVP's site is located at <http://www.uvp.com>



<http://www.uvp.com>

Corporate Headquarters: UVP, Inc. 2066 W. 11th Street, Upland CA 91786
Tel: (800)452-6788 or (909)946-3197 **Fax:** (909)946-3597 **E-Mail:** uvp@uvp.com

European Sales Operations: Ultra-Violet Products Limited
Science Park, Milton Road, Cambridge, UK CB4 4FH **Tel:** +44(0)1223-420022
Fax: +44(0)1223-420561 **E-Mail:** uvp@dial.pipex.com

81-0161-01 Rev A