

NATIONAL AERONAUTICS AND SPACE ADMINISTRATION

SPACE SHUTTLE MISSION STS-61

PRESS KIT
DECEMBER 1993



HUBBLE SPACE TELESCOPE SERVICING MISSION-01

STS-61 INSIGNIA

STS061-S-001 -- Designed by the crewmembers, the STS-61 insignia depicts the astronaut symbol superimposed against the sky with the Earth underneath. Also are two circles representing the optical configuration of the Hubble Space Telescope (HST). Light is focused by reflections from a large primary mirror and a smaller secondary mirror. The light is analyzed by various instruments and, according to the crewmembers, "brings to us on Earth knowledge about planets, stars, galaxies and other celestial objects, allowing us to better understand the complex physical processes at work in the universe." The space shuttle Endeavour is also represented as the fundamental tool that allows the crew to perform the first servicing of the Hubble Space Telescope so its scientific deep space mission may be extended for several years to come. The overall design of the insignia, with lines converging to a high point, is also a symbolic representation of the large-scale Earth-based effort--which involves space agencies, industry and the universities--to reach goals of knowledge and perfection.

The NASA insignia design for space shuttle flights is reserved for use by the astronauts and for other official use as the NASA Administrator may authorize. Public availability has been approved only in the form of illustrations by the various news media. When and if there is any change in this policy, which we do not anticipate, it will be publicly announced.

PHOTO CREDIT: NASA or National Aeronautics and Space Administration.

PUBLIC AFFAIRS CONTACTS

For Information on the Space Shuttle

Ed Campion NASA Headquarters Washington, DC	Policy/Management	202/358-1778
James Hartsfield Johnson Space Center Houston, TX	Mission Operations Astronauts	713/483-5111
Bruce Buckingham Kennedy Space Center, Fl	Launch Processing KSC Landing Information	407/867-2468
June Malone Marshall Space Flight Center Huntsville, AL	External Tank/SRBs/SSMEs	205/544-0034
Nancy Lovato Dryden Flight Research Center Edwards, CA	DFRC Landing Information	805/258-3448

For Information on STS-61 Payloads

Sarah Keegan NASA Headquarters Washington DC	HST Program/Science	202/358-1547
Debra Rahn NASA Headquarters Washington, DC	HST International Elements	202/358-1639
Jim Elliot Goddard Space Flight Center Greenbelt, MD	HST Project/Science/STOCC Operations	301/286-6256
Michael Finneran Goddard Space Flight Center Greenbelt, MD	HST Project/Science/STOCC Operations	301/286-5565
Bob MacMillin Jet Propulsion Laboratory Pasadena, CA	Wide Field/Planetary Camera II	818/354-5011
Jean Paul Paille ESA NASA Headquarters Paris, France	European Space Agency	011 33 1 42 73 72 92
Ray Villard Space Telescope Science Institute Baltimore, MD	HST Science, COSTAR	410/338-4514

CONTENTS

GENERAL BACKGROUND MATERIAL

General Release	5
Media Services Information	6
Quick-Look Facts	7
Shuttle Abort Modes	8
Vehicle And Payload Weights	9
Summary Timeline	11
Orbital Events Summary	12

CARGO BAY PAYLOADS & ACTIVITIES

HST Servicing Mission-01 (HST/SM-01) Overview	13
History of HST	13
Mission Objectives And Success	14
First Corrected Image Availability	14
Science Accomplishments	15
ESA Role in HST Program	16
Servicing Mission Orbital Verification	17
Key Hubble Scientific Goals Following the First Servicing Mission	18
Hubble Space Telescope Rendezvous and Retrieval	19
Commands to Hubble	19
STS-61 Extravehicular Activities	20
Replacement Hardware and Instruments	21
Primary Servicing Tasks	24
Secondary Servicing Tasks	33
HST Tools and Crew Aids	34

IN-CABIN PAYLOADS

IMAX Camera	42
Air Force Maui Optical System (AMOS)	43
DTO-667 Pilot Inflight Landing Operations Trainer (PILOT)	43

STS-61 CREW BIOGRAPHIES	44
--------------------------------	----

ACRONYMS AND ABBREVIATIONS	47
-----------------------------------	----

RELEASE: 93-204

FIVE SPACEWALKS TO SERVICE HUBBLE SPACE TELESCOPE HIGHLIGHTS SHUTTLE MISSION STS-61

The December flight of Endeavour on Space Shuttle Mission STS-61 will see the first in a series of planned visits to the orbiting Hubble Space Telescope (HST). The 11-day mission has been designed to accommodate a record five spacewalks with the capability for an additional two if needed.

The first HST servicing mission has three primary objectives: restoring the planned scientific capabilities, restoring reliability of HST systems and validating the HST on-orbit servicing concept. These objectives will be accomplished in a variety of tasks performed by the astronauts in Endeavour's cargo bay.

Replacement of the spacecraft's solar arrays - HST's source of electrical power - tops the primary servicing task list. This is because solar array jitter, or excessive flexing which happens when the telescope passes from cold darkness into warm daylight, may be compromising the structural integrity of the arrays.

The objective to restore the HST's science capabilities will be accomplished with the installation of the Wide Field/Planetary Camera-II and the Corrective Optics Space Telescope Axial Replacement, both of which will compensate for the spherical aberration of the primary mirror.

The installation of new gyroscopes, which are required to point and track HST, along with fuse plugs and electronic units will increase the reliability of the HST system.

Leading the seven-person STS-61 crew will be Mission Commander Dick Covey. Pilot for the mission is Ken Bowersox. The mission specialists for the flight are Kathy Thornton, Claude Nicollier, Jeff Hoffman, Story Musgrave and Tom Akers. Working in pairs, Hoffman and Musgrave and Thornton and Akers, all of whom have previous EVA experience, will perform the five spacewalks scheduled for flight days 4-8.

Launch of Endeavour on the STS-61 mission is currently scheduled for no earlier than Dec. 1, 1993 at 4:57 a.m. EST. The planned mission duration is 10 days, 22 hours and 36 minutes. An on-time launch on Dec. 1 would produce a 3:33 a.m. EST landing on Dec. 12 at Kennedy Space Center's Shuttle Landing Facility.

STS-61 will be the 5th flight of Space Shuttle Endeavour and the 59th flight of the Space Shuttle system. The Hubble Space Telescope is an international cooperative program between NASA and the European Space Agency.

(END OF GENERAL RELEASE; BACKGROUND INFORMATION FOLLOWS.)

STS-61 MEDIA SERVICES INFORMATION

NASA Select Television Transmission

NASA Select television is available on Satcom F-2R, Transponder 13, located at 72 degrees west longitude; frequency 3960.0 MHz, audio 6.8 MHz.

The schedule for television transmissions from the orbiter and for mission briefings will be available during the mission at Kennedy Space Center, Fla.; Marshall Space Flight Center, Huntsville, Ala.; Ames-Dryden Flight Research Facility, Edwards, Calif.; Johnson Space Center, Houston and NASA Headquarters, Washington, D.C. The television schedule will be updated to reflect changes dictated by mission operations.

Television schedules also may be obtained by calling COMSTOR 713/483- 5817. COMSTOR is a computer data base service requiring the use of a telephone modem. A voice update of the television schedule is updated daily at noon Eastern time.

Status Reports

Status reports on countdown and mission progress, on-orbit activities and landing operations will be produced by the appropriate NASA newscenter.

Briefings

A mission press briefing schedule will be issued prior to launch. During the mission, status briefings by a Flight Director or Mission Operations representative and when appropriate, representatives from the science team, will occur at least once per day. The updated NASA Select television schedule will indicate when mission briefings are planned.

STS-61 QUICK LOOK

Launch Date/Site: Dec. 1, 1993/Kennedy Space Center, Fla., Pad 39B
Launch Time: 4:57 a.m. EST (approximate)
Orbiter: Endeavour (OV-105) 5th Flight
Orbit/Inclination: 320 nautical miles/28.45 degrees
Mission Duration: 10 days, 22 hours, 36 minutes (approximate)
Landing Time/Date: 3:33 a.m. EST (approximate)/Dec. 12, 1993
Primary Landing Site: Kennedy Space Center, Fla.
Abort Landing Sites: Return to Launch Site: KSC, Fla.
Trans-Atlantic Abort Landing: Banjul, The Gambia
Moron, Spain
Ben Guerir, Morocco
Abort Once Around: Edwards AFB, Calif.

Crew: Dick Covey, Commander (CDR)
Ken Bowersox, Pilot (PLT)
Kathy Thornton, Mission Specialist 1 (MS1/EV3)
Claude Nicollier, Mission Specialist 2 (MS2)
Jeff Hoffman, Mission Specialist 3 (MS3/EV1)
Story Musgrave, Mission Specialist 4 (MS4/EV2)
Tom Akers, Mission Specialist 5 (MS5/EV4)

Cargo Bay Payloads: HST SM-01 (Hubble First Servicing Mission)

HST Replacements: SA (Solar Arrays)
WF/PC-II (Wide Field/Planetary Camera-II)
RSU-1, 2 & 3 (Rate Sensor Units 1, 2 and 3)
ECU-1 & 3 (Electronic Control Units 1 and 3)
MSS-1 & 2 (Magnetic Sensing Systems 1 and 2)
COSTAR (Corrective Optics Space Telescope Axial Replacement)
SADE (Solar Array Drive Electronics)

Cargo Bay Equip: HST FSS (HST Flight Support System)
ORUC (Orbital Replacement Unit Carrier)
SAC (Solar Array Carrier)
SIPE (Scientific Instrument Protective Enclosures)
ICBC (IMAX Cargo Bay Camera)

In-Cabin Payloads: IMAX (IMAX In-Cabin Camera)

Other: AMOS (Air Force Maui Optical Site)

DTOs/DSOs

DTO 648:	Electronic Still Camera	DTO 656:	PGSC Upset Monitoring
DTO 700-2:	Handheld Laser Ranging Device	DTO 700-8:	Global Positioning System Flight Test
DTO 1211:	Water Dumps at 10.2 psi Cabin	DSO 326:	Window Impact Observation
DSO 469:	Inflight Radiation Dose/Distribution	DSO 483:	Back Pain in Microgravity
DSO 485:	Inter-Mars Tissue Equivalent Counter	DSO 487:	Immunological Assessment of Crew
DSO 489:	EVA Dosimetry Evaluation	DSO 604:	Visual-Vestibular/Function of Adaptation
DSO 617:	Skeletal Muscle Performance	DSO 624:	Cardiovascular Response to Exercise
DSO 901:	Documentary Television	DSO 902:	Documentary Motion Picture
DSO 903:	Documentary Still Photography		

STS-61 SPACE SHUTTLE ABORT MODES

Space Shuttle launch abort philosophy aims toward safe and intact recovery of the flight crew, orbiter and its payload. Abort modes include:

- Abort-To-Orbit (ATO) - Partial loss of main engine thrust late enough to permit reaching a minimal 105-nautical mile orbit with orbital maneuvering system engines.
- Abort-Once-Around (AOA) - Earlier main engine shutdown with the capability to allow one orbit around before landing at Edwards Air Force Base, Calif.
- Trans-Atlantic Abort Landing (TAL) - Loss of one or more main engines midway through powered flight would force a landing at either Banjul, The Gambia, Moron, Spain, or Ben Guerir, Morocco.
- Return-To-Launch-Site (RTL) - Early shutdown of one or more engines, and without enough energy to reach Banjul, would result in a pitch around and thrust back toward KSC until within gliding distance of the Shuttle Landing Facility.

STS-61 contingency landing sites are the Kennedy Space Center, Edwards Air Force Base, Banjul, Moron or Ben Guerir.

STS-61 VEHICLE AND PAYLOAD WEIGHTS

	<u>Pounds</u>
Orbiter (Endeavour) empty and 3 SSMEs	173,014
Flight Support System (FSS)	4,200
IMAX Cargo Bay Camera (ICBC)	608
IMAX (in cabin)	329
Orbital Replacement Unit Carrier (ORUC)	6369
Solar Array Carrier (SAC)	3829
Solar Array II	702
Rate Sensor Units (3)	73
Wide Field/Planetary Camera II	613
Corrective Optics Space Telescope Axial Replacement	660
Electronic Control Units (2)	35
Magnetic Sensing System (2)	30
Co-processor	140
Goddard High Resolution Spectrograph Redundancy Kit	7
Changeout complement total (launch)	2300
High-Speed Photometer	603
WF/PC I	624
Solar Array I	668
RSU (3)	73
ECU (2)	35
Changeout complement total (Earth return)	2135
DSOs/DTOs	104
Total Vehicle at SRB Ignition	4,511,115
Orbiter Landing Weight	209,383

NASA Space Shuttle Program STS-61 Cargo Configuration

(HST SM-1)

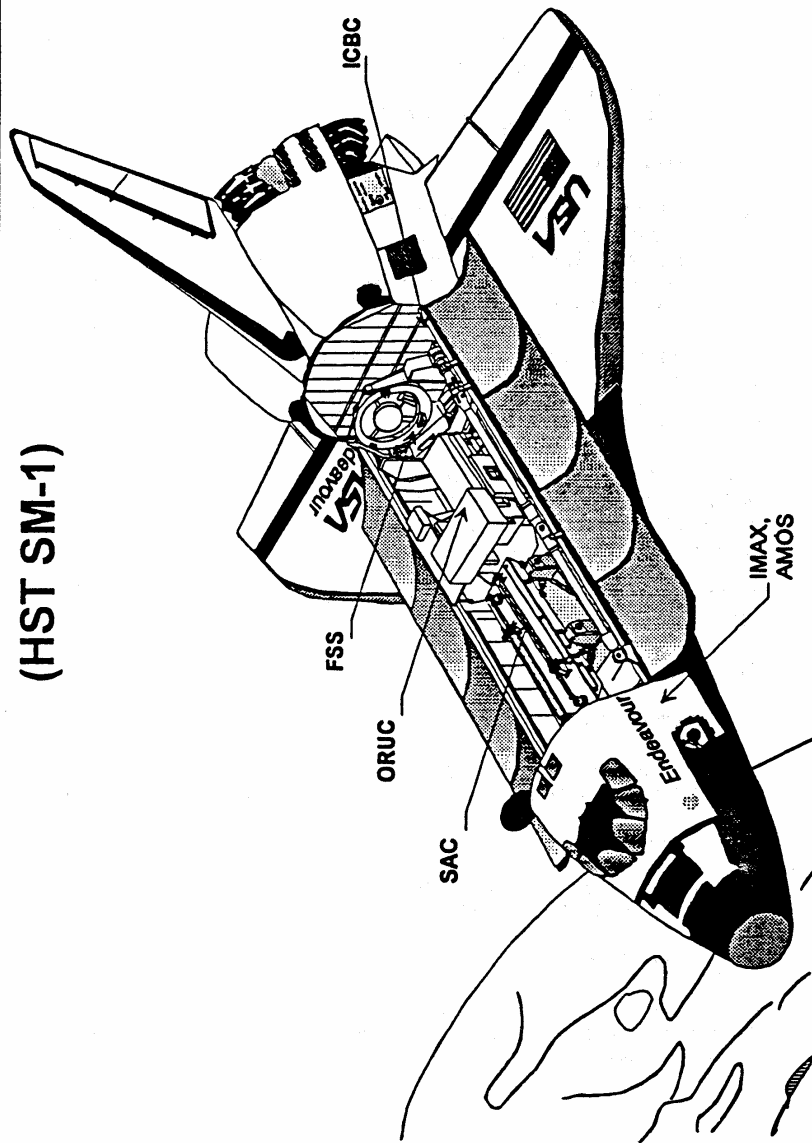

STS-61 SUMMARY TIMELINE*

Flight Day 1

Ascent
OMS-2 burn (310 n.m. x 297 n.m.)
ICBC activation
NC-1 burn (310 n.m. x 302 n.m.)

Flight Day 2

Remote Manipulator System checkout
Cabin pressurization to 10.2 psi
Space Support Equipment checkout/survey
Configure Flight Servicing Structure
NPC burn (310 n.m. x 302 n.m.)
NSR burn (310 n.m. x 304 n.m.)
Extravehicular Mobility Unit checkout
NC-2 burn (317 n.m. x 305 n.m.)

Flight Day 3

HST rendezvous operations
NH burn (320 n.m. x 305 n.m.)
NC-3 burn (320 n.m. x 310 n.m.)
NCC burn (320 n.m. x 310 n.m.)
TI burn (320 n.m. x 312 n.m.)
HST grapple (320 n.m. x 313 n.m.)
HST berth
HST survey
Group B powerdown

Flight Day 4

HST Extravehicular Activity 1
(Hoffman and Musgrave: Two Rate Sensor
Units/Secondaries)

Flight Day 5

HST Extravehicular Activity 2
(Thornton and Akers: Solar Arrays)

Flight Day 6

HST Extravehicular Activity 3
(Hoffman and Musgrave: Wide Field/Planetary
Camera; Two Magnetic
Sensing Systems)

Flight Day 7

HST Extravehicular Activity 4
(Thornton and Akers: Corrective Optics Space Telescope Axial
Replacement/Secondaries)

Flight Day 8

HST reboost burns (320 n.m. x 313 n.m.)
HST Extravehicular Activity 5
(Hoffman and Musgrave: Solar Array Drive Electronics/Secondaries)

Flight Day 9

Group B power up
HST grapple
HST unberth
HST release (320 n.m. x 313 n.m.)
Separation burns 1, 2 and 3 (320 n.m. x 311 n.m.)
Group B power down

Flight Day 10*

Cabin pressurization to 14.7 psi
Off-duty half day (MS1, MS3, MS4, MS5)
Off-duty half day (CDR, PLT, MS2)

Flight Day 11

Group B power up
Flight Control Systems checkout
Reaction Control System hot fire
Cabin stow

Flight Day 12

Space Support Equipment power down
Deorbit preparations
Deorbit burn
Entry
Landing

*SPECIAL NOTE ON STS-61 SUMMARY TIMELINE

On every Shuttle mission, some day-to-day replanning takes place to adjust crew and event timelines according to unforeseen developments or simply to optimize the use of time in orbit.

During STS-61, the bulk of the daily replanning will be undertaken, while the crew sleeps, by the planning shift in mission control. During the EVA days, this team will play a crucial role in making the most of the astronauts time in Endeavour's payload bay. To maximize crew productivity and to adapt to any unexpected challenges, the planning team will have the ability to reorder the sequence of individual tasks within any given spacewalk or to shift tasks from one day's agenda to another.

Each day's replanning effort will produce an execute plan defining the approach for the next day's activities in space and on the ground.

STS-61 ORBITAL EVENTS SUMMARY

Event	Start Time (dd/hh:mm:ss)	Velocity Change (feet per second)	Orbit (n.m.)	Notes
OMS-2	00/00:45:00	461	310 x 297	
NC-1	00/05:33:00	8	310 x 302	Adjusts the rate at which Endeavour is closing on HST
NPC	00/23:12:00	.5	310 x 302	Fine-tunes Endeavour's ground track to be exactly in line with HST track
NSR	01/03:57:00	5.5	310 x 304	Adjusts Endeavour's closing rate on HST
NC-2	01/04:32:00	12	317 x 305	Adjusts Endeavour's closing rate on HST
NH	01/17:22:00	4	320 x 305	Adjusts altitude of Endeavour's orbital high point, fine-tunes course to arrive at a point 40 nautical miles behind HST at same altitude
NC-3	01/18:10:00	10	320 x 310	Fired at 40 n.m. behind HST, begins closing in on HST; initiates closing rate of about 16 n.m. per orbit aimed to arrive at a point 8 n.m. behind HST, at same altitude as HST, two orbits later
NCC	01/20:23:00	TBD	320 x 310	First burn calculated by onboard computers using onboard navigation derived from orbiter star tracker sightings of HST; fired while orbiter is about closing on point 8 n.m. behind HST to fine-tune course
TI	01/21:23:00	3	320 x 312	Fired upon arrival at point 8 n.m. behind HST; begins terminal interception of HST
MC1-MC4	TBD	TBD	TBD	Mid-course corrections; calculated by onboard computers, double-checked by ground; fine-tune final course toward HST, may or may required
MANUAL	01/22:57:00	TBD	TBD	Begins about 45 minutes prior to HST grapple, less than 1 nautical mile from HST. Commander takes manual control of orbiter flight, fires braking maneuvers to align and slow final approach
GRAPPLE	01/23:42:00	n/a	n/a	HST captured with mechanical arm
HST REBOOST	06/17:45:00	TBD	TBD	Performed only if amount of available propellant allows, lifts Endeavour's orbit to reboost HST's orbit while HST is in cargo bay
HST REBOOST	06/18:33:00	TBD	TBD	Performed only if amount of available propellant allows, lifts Endeavour's orbit to reboost HST's orbit while HST is in cargo bay
HST RELEASE	08/00:43:00	n/a	n/a	HST is released from Endeavour's mechanical arm
SEP-1	08/00:44:00	1	320 x 313	Begins a slow separation of Endeavour from vicinity of HST
SEP-2	08/01:08:00	2	320 x 313	Increases rate at which Endeavour is departing vicinity of HST
SEP-3	08/01:32:00	3	320 x 311	Puts Endeavour on final course departing vicinity of HST
DEORBIT	10/20:31:00	508		
LANDING	10/21:45:00			

NOTE: All planned burns are recalculated in real time once the flight is underway using the latest information for the position of HST and will likely change slightly. Depending on how accurate the orbiter's navigation and course is at certain times, some smaller burns listed above may not be required. However, the times for major burns and events are unlikely to change by more than a few minutes.

HUBBLE SPACE TELESCOPE/SERVICING MISSION-01 (HST-SM-01)

OVERVIEW OF MISSION

History

Launched on April 24, 1990, NASA's Hubble Space Telescope was designed to be the most powerful astronomical observatory ever built. And indeed, HST far surpasses the capabilities of ground-based optical telescopes for many types of research. The keys to Hubble's power are its operation in space, far above the interference of the Earth's atmosphere, and to the unique instruments it carries as it orbits the planet. In addition HST was the first observatory designed for extensive on-orbit maintenance and refurbishment.

While the launch on the Space Shuttle Discovery more than 3 years ago was flawless, Hubble was not. Two months after HST was deployed into orbit 370 miles (595.5 km) high, Hubble produced a disquieting discovery not about space, but about itself. The curvature of its primary mirror was slightly - but significantly - incorrect. Near the edge, the mirror is too flat by an amount equal to 1/50th the width of a human hair.

A NASA investigative board later determined that the flaw was caused by the incorrect Adjustment of a testing device used in building the mirror. The device, called a "null corrector," was used to check the mirror curvature during manufacture.

The result is a focusing defect or spherical aberration. Instead of being focused into a sharp point, light collected by the mirror is spread over a larger area in a fuzzy halo. Images of extended objects, such as stars, planets and galaxies, are blurred.

NASA has been coping with Hubble's fuzzy vision with computer processing to sharpen images. For bright objects, this technique has yielded breathtaking detail never seen from the ground. NASA also has been concentrating on the analysis of ultraviolet light, which ground-based telescopes cannot see because of the Earth's intervening atmosphere.

To realize the full potential of HST, however, the spacecraft must be serviced. The telescope mirror itself cannot be fixed or changed. However, corrective optics can be applied to the HST instruments to compensate for the aberration, much the same as glasses or contact lenses correct human sight. The new optics should allow Hubble to accomplish most, if not all, of its originally planned objectives.

The mission, though, will accomplish much more than improved vision. Hubble was designed to spend 15 years in space. Even before the spherical aberration was known, several servicing missions, including one in 1993, had been planned so that failed parts could be replaced and others improved with better technology. This mission will perform that type of servicing in addition to installing corrective optics.

Endeavour will carry some 16,000 pounds (7,257 kilograms) of servicing hardware into space. During nearly 2 weeks in orbit around the Earth, astronauts will use the Shuttle as a kind of orbiting service station from which they will venture to work on the 12.5-ton (11.34-metric ton) telescope as it hurtles around the planet at 18,000 miles (28,968 km) an hour.

The crew will spend some 30 hours in space during at least five separate spacewalk periods, undertaking a series of tasks more complex than any ever attempted in orbit, to ensure that Hubble remains a viable and productive national resource throughout its planned 15-year lifetime.

Mission Objectives and Success

The three objectives of the first Hubble servicing mission are to restore the planned capabilities of the telescope by correcting the optics, to restore reliability of the spacecraft and to validate that the concept of Hubble on-orbit servicing is viable.

The top priorities are installation of the replacement solar arrays; two rate sensing units, one with an electronics control unit; the Wide Field/Planetary Camera II (WF/PC-II) and fuses; the Corrective Optics Space Telescope Axial Replacement (COSTAR); at least one new magnetometer; and a new Solar Array Drive Electronics unit.

For the first servicing mission to be considered fully successful, these top priority items must be accomplished. In addition, other tasks may be performed on a time-available basis. The minimum criteria for mission success are to leave Hubble with three newer-design gyroscope systems and either an operational WF/PC-II or COSTAR.

First Corrected Image Availability

The first fully corrected Hubble images are estimated to be available 6 to 8 weeks after the servicing mission. This time is necessary for Adjustments to ensure telescope stability and the best possible focus. During this period, telescope operators on the ground will remotely calibrate the gyros, which help keep the HST fixed on its targets, and position the corrective mirrors in the Corrective Optics Space Telescope Axial Replacement (COSTAR) and the Wide Field/Planetary Camera 2 (WF/PC-II).

COSTAR is being installed to remedy the blurred vision of three observing instruments on HST. The WF/PC-II is a replacement camera that has its own corrective optics.

More information on activities after STS-61 necessary to produce a fully corrected Hubble image can be found in the section on Servicing Mission Orbital Verification.

Science Accomplishments

Despite the flaw in the primary mirror, the bus-size Hubble still has been able to gather a wealth of scientific data, most of which would have been impossible to collect if the telescope did not exist. In the last 3 years, HST has conducted a variety of scientific investigations that have rapidly expanded knowledge of what lies beyond the Earth, from the relatively nearby planets in Earth's solar system to the most distant reaches of the universe.

Hubble's studies have ranged from Earth's neighbor Mars, to the evolution of stars from birth to death, to the characteristics of galaxies beyond, and finally to a field known as cosmology, which probes the fundamental nature of the universe itself.

The following is a small sampler of some of Hubble's discoveries and work in progress:

- **The Planets**

Even prior to the servicing mission, Hubble conducted and continues to conduct long-term observations of global weather changes on Mars. Hubble has observed the development of a rare, planet-wide storm on Saturn. The telescope also resolved, as two distinct objects, the most distant planet in the solar system, Pluto and its moon Charon. Previously, no telescope had been able to separate clearly the two bodies.

HST also has been studying long-term weather changes on Jupiter and its auroral activity. Hubble also has been measuring the extent of the atmosphere of the Jovian moon Io and also has looked for changes in the satellite's surface.

- **Stellar Evolution**

Hubble uncovered the strongest evidence yet that many stars form planetary systems. This evidence was the discovery of disks of dust around 15 newly formed stars in the Orion Nebula, a starbirth region 1,500 light-years away. Such disks are considered a prerequisite for the formation of solar systems like Earth's. The HST images confirm more than two centuries of speculation, conjecture and theory about the genesis of a solar system.

- **Star Clusters**

HST discovered young globular star clusters at the core of a peculiar galaxy. The discovery of these stars early in their evolution was the equivalent of finding a "Jurassic Park" in space.

The space telescope found "blue straggler" stars in the core of globular cluster 47 Tucanae, providing evidence that some stars "capture" others and merge with them.

- **Galaxies**

HST uncovered circumstantial evidence for the presence of a massive black hole in the core of the neighboring galaxy M32 as well as the giant elliptical galaxy M87. Both galaxies have a central concentration of starlight that probably is shaped by the gravitational field of the black hole. This implies that massive black holes may be quite common among "normal" galaxies, perhaps even Earth's.

Hubble yielded direct evidence for galaxy evolution by resolving the shapes of galaxies that existed long ago. HST revealed that many ancient spiral galaxies have since disappeared, possibly through fading or collisions and mergers with other galaxies.

- **Cosmology**

The space telescope allowed astronomers to take a major first step in determining the rate at which the universe is expanding. HST detected 27 stars called Cepheid variables. These stars are "standard candles" for estimating distances to galaxies. The expansion rate, known as the Hubble Constant, is one of two critical numbers needed for making a precise determination of the size, age and fate of the universe.

HST discovered boron, the fifth lightest element, in a very ancient star. This star would have been one of the earliest formed after the Big Bang explosion that most scientists believe began the universe. If boron was produced in the first few minutes of the birth of the universe, it implies that the Big Bang was not a uniform explosion.

Hubble precisely determined the ratio of deuterium to hydrogen in interstellar gas clouds. This value shows that the universe has only 6 percent of the observable matter required to prevent itself from expanding forever.

European Space Agency (ESA) Role in HST

The Hubble Space Telescope is a program of joint cooperation between NASA and ESA. ESA provided Hubble's deployable solar arrays, the major source of electrical power, which collects energy from the sun to recharge the spacecraft's six nickel-hydrogen batteries. ESA's second contribution was the Faint Object Camera (FOC), which was intended for imaging of the faintest objects in the visible and ultraviolet spectral regions at very high spatial resolution. These elements are discussed further in the section addressing replacement hardware and instruments.

Claude Nicollier, a mission specialist on this flight, is an ESA astronaut.

SERVICING MISSION ORBITAL VERIFICATION (SMOV)

The purpose of SMOV is to “recommission” HST so that it can begin science operations as soon as possible following the first servicing mission. This involves a thorough engineering checkout of all serviced subsystems; optical alignment and initial calibration of all science instruments; and the phasing in of astronomical observations. SMOV begins when HST is released from the Shuttle and is expected to last approximately 13 weeks.

Key Activities During SMOV

- Activation and engineering checkout of the science instruments.
- Optical alignment and focusing of WF/PC-II and COSTAR.
- Initial calibration of WF/PC-II and the COSTAR-corrected science instruments.
- Early science observations.

Engineering Checkout Activities

- Decontaminate the WFPC II detectors (charge-coupled devices or CCDs) of any foreign substances by heating the detectors to “drive-off” contaminants.
- Establish proper operating temperature of WFPC II CCDs by monitoring ultraviolet (UV) light from a calibration star.
- Monitor pressure drop (due to outgassing) until it is safe to turn on high voltage to the COSTAR-corrected science instruments.
- Determine the effects of the servicing mission on the basic (pre-COSTAR) optical performance of the science instruments.

Steps in Focusing the Science Instruments

- Check out the first generation instruments and conduct prefocusing tests.
- Adjust the secondary mirror in HST’s Optical Telescope Assembly to set focus for WF/PC-II and correct for residual coma in the Optical Telescope Assembly.
- Deploy COSTAR arms.
- Adjust COSTAR and WF/PC-II optics and mirrors, including mirror tilt, coarse Adjustment, fine alignment and focus.

Science Instruments Calibration

- A series of tests and measurements to establish the actual performance of the science instruments in the areas of sensitivity, resolution and detector response characteristics.

KEY HST SCIENTIFIC GOALS FOLLOWING THE FIRST SERVICING MISSION

- Hubble will determine, precisely, the expansion rate of the universe by measuring the light curve of Cepheid Variable stars in galaxies out to the distance of at least 50 million light-years.

Cepheids are pulsating stars that become alternately brighter and fainter with periods (duration of the states of brightness or faintness) ranging from 10 to 50 days. Astronomers have known for over 50 years that the periods of these stars precisely predict their total luminous power, which allows their distance to be measured.

In the expanding universe, the Hubble Constant (H_0) is the ratio of the recession velocities of galaxies to their distance. (Recession velocity is the speed at which the galaxy is moving away from Earth.) The age of the universe can be estimated from the Hubble Constant. The age currently is estimated to be between 10 and 20 billion years, but a more precise measurement of the Hubble Constant is required to narrow this range to an accuracy of 10 percent.

- HST will look for the gravitational signature of massive black holes in the cores of normal and active galaxies. A black hole is a theoretical object that is so compact and dense, nothing can escape its gravitational field. The HST spectrographs will measure precisely the velocities of gas and stars orbiting the center of a galaxy. If the stellar velocities increase rapidly toward the galaxy center, it would be the signature of a massive, compact central object.
- Hubble will be able to determine the shapes of galaxies that are very distant. Because remote objects also are relics of the early universe, HST will be able to study how galaxies have evolved since the beginning of the universe. Nearby galaxies have spiral, elliptical and irregular shapes, however, these shapes should have changed over time because the universe is evolving.
- Hubble will be able to precisely measure the ages of globular clusters by observing the faintest stars in the clusters. Globular clusters are considered to be the oldest objects in the universe, and their ages provide insights into how stars evolve and also provide an independent estimate of the age of the universe.

HUBBLE SPACE TELESCOPE RENDEZVOUS AND RETRIEVAL

The rendezvous and retrieval operational procedures for the Hubble Space Telescope will be similar to those conducted on previous missions requiring capture of a free-flying satellite in orbit.

For the HST mission, Endeavour's crew will perform many orbit Adjust burns to catch up with and retrieve the telescope on flight day three of the mission using the Shuttle's robot arm.

Once the Shuttle is safely in orbit and the payload bay doors opened, the space support equipment activation is performed. This includes activating the flight support system and orbital replacement unit carrier heaters. Other pre-rendezvous activities will include checkout of the robot arm, the orbiter Ku-band dish antenna used as a radar system during rendezvous and the ground command system.

The terminal initiation burn occurs about 2 hours prior to capture at a distance of approximately 40,000 feet (12,192 m) in front of the telescope. Several small mid-course correction burns follow before the Commander takes over manual control of the Shuttle about 1,200 feet (366 m) below and 500 feet (152 m) behind the telescope.

The orbiter approaches Hubble from underneath, just after orbital sunset. This approach technique is designed to minimize potential contamination from the Shuttle's thruster firings.

Prior to capture, a ground-commanded maneuver of the telescope will be performed to align the grapple fixture on the HST with Endeavour's robot arm. The size of the telescope maneuver will depend on the angle to the Sun and ranges from about 70 degrees to 180 degrees.

When the telescope is grappled, using the robot arm's end effector, it will be lowered into the payload bay and berthed in the flight support system, a turntable likened to a lazy susan for its rotation and tilt ability to assist in the servicing tasks. An electrical cable is remotely attached to provide orbiter power to the telescope.

COMMANDS TO HUBBLE

Commands to HST are issued from the Space Telescope Operations Center (STOCC) at Goddard Space Flight Center, Greenbelt, Md., which manages the orbiting observatory. The STOCC has been the nerve center for Hubble operations since the telescope was launched. Commands to Hubble are issued from the STOCC and data gathered by the spacecraft arrive there first.

The STOCC is responsible for most commanding of the HST during STS-61, although the crew can send a limited number of commands from Endeavour. The STOCC will send commands configuring the space telescope for retrieval by the orbiter; integrate commands with crew activities during extravehicular activities (EVAs) to configure various spacecraft hardware and perform hardware checkouts and send commands to configure the space telescope for deployment from Endeavour.

STS-61 EXTRAVEHICULAR ACTIVITIES

A total of five spacewalks are planned on STS-61 to service the HST. Unlike past Shuttle repair work performed on satellites such as Intelsat on STS-49, HST was designed with the objective of servicing it in orbit through Shuttle spacewalks. As such, it has two grapple fixtures for the Shuttle's mechanical arm, many handholds for spacewalkers and bolts and electrical connections designed to be serviced by a spacewalker.

However, the amount of work to be performed on STS-61 has increased above what originally was projected for the first servicing flight to the telescope due to deficiencies and equipment problems that have occurred or been discovered since HST was launched. Since there is such a large amount of work to be accomplished on STS-61, the various tasks have been prioritized by the HST program officials.

The primary tasks on STS-61 will be to install two Rate Sensor Units, one with an Electronics Control Unit, the Solar Arrays, the Solar Array Drive Electronics, the Wide Field/Planetary Camera and four instrument fuse plugs, the Corrective Optics Space Telescope Axial Replacement and one Magnetic Sensing System.

Secondary tasks that may be performed during the spacewalks if time permits include installing the Goddard High Resolution Spectrograph Redundancy Kit, a 386 coprocessor, a second Magnetic Sensing System, four gyro Fuse Plugs and one Electronic Control Unit. A third Rate Sensor Unit is being carried in the payload bay for use if needed.

The spacewalks will be performed by STS-61 extravehicular crew members Jeff Hoffman, Story Musgrave, Kathy Thornton and Tom Akers. Each spacewalk will be performed by two crew members, one of whom will be in a foot restraint mounted at the end of Endeavour's mechanical arm. During all EVAs, the crew member mounted at the end of the arm will be referred to as Extravehicular Crew Member 2, or EV2, while the other spacewalker will be designated EV1.

The EVA crew can be distinguished by markings on the legs of their spacesuits. Hoffman will have a solid red stripe around the legs of his suit; Musgrave will have no stripes on the legs of his suit; Thornton will have a dashed red stripe around the legs of her suit; and Akers will have a diagonal, broken red stripe around the legs of his suit.

In planning for the mission, the EVAs have been designed to take into account the possibility that crew members may encounter unforeseen difficulties either in tasks or equipment that could cause the preplanned schedule for installation of various equipment to change. All four EV crew members have cross-trained so that any one is capable of performing any given task.

For all of the various tasks, the Flight Support Structure in Endeavour's cargo bay on which HST will be mounted, once it is retrieved, will be rotated so the area being worked on faces forward to allow better visibility. Those specific tasks and the EVA work required to complete them are described in the following sections.

REPLACEMENT HARDWARE AND INSTRUMENTS

While the servicing mission is complex, steps have been taken to make the spacecraft as straightforward to work on as possible. Since HST was designed for servicing in space from its inception, many of its subsystems are modular, standardized and accessible. Hubble has 49 different modular subsystems designed for servicing, ranging from small fuses to large scientific instruments. The space telescope, which is 43.5 feet (13.25 meters) long, also has 225 feet (69 meters) of handrails and 31 footholds to aid astronauts in servicing tasks. And more than 200 tools - from screwdrivers to hardware designed specifically for HST servicing - are available for use on this mission.

NASA's Goddard Space Flight Center, Greenbelt, Md., is responsible for the components that will be serviced or replaced on Hubble. The components make up a primary servicing task list that will be carried out during the mission, followed by a secondary task list to be undertaken if time and conditions allow.

The mission's primary objective is to restore the HST's science capabilities with the Wide Field/Planetary Camera-II and the Corrective Optics Space Telescope Axial Replacement, both of which will compensate for the spherical aberration of the primary mirror.

However, the replacement of the spacecraft's solar arrays - HST's major source of electrical power - tops the primary servicing task list. This is because solar array jitter, or excessive flexing, may be compromising the structural integrity of the arrays. By replacing the arrays first, the observatory still will be able to perform science even if an emergency causes the mission to be called off and forces astronauts to release the telescope from the Space Shuttle before installing the optics packages

Likewise the replacement of one gyro pair is second on the task list, because if more gyros fail, the pointing of the spacecraft at science targets cannot be accurately controlled.

The primary servicing task list includes:

- Solar Array II (SA II).
- Gyro Pair 2.
- Wide Field Planetary Camera 2 (WFPC2) and four instrument fuse plugs.
- Corrective Optics Space Telescope Axial Replacement (COSTAR)
- Magnetometer System 1.
- Gyro Pair 3 with Electronics Control Unit (ECU).
- Solar Array Drive Electronics 1 (SADE).

The secondary servicing task list includes:

- A redundancy kit for the Goddard High Resolution Spectrograph (GHRS).
- The 386 co-processor on the spacecraft's primary computer, called the DF-224.
- Magnetometer System 2
- Four gyro fuse plugs.
- Electronics Control Unit for Gyro Pair 1.

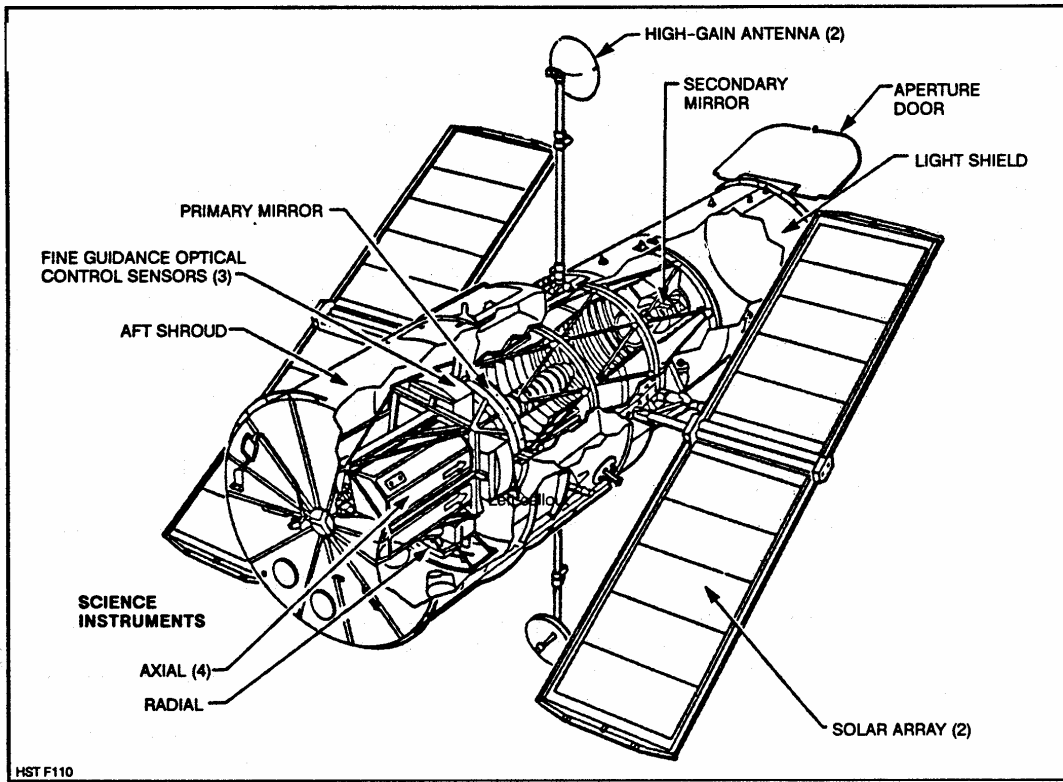

OVERALL HUBBLE SPACE TELESCOPE CONFIGURATION

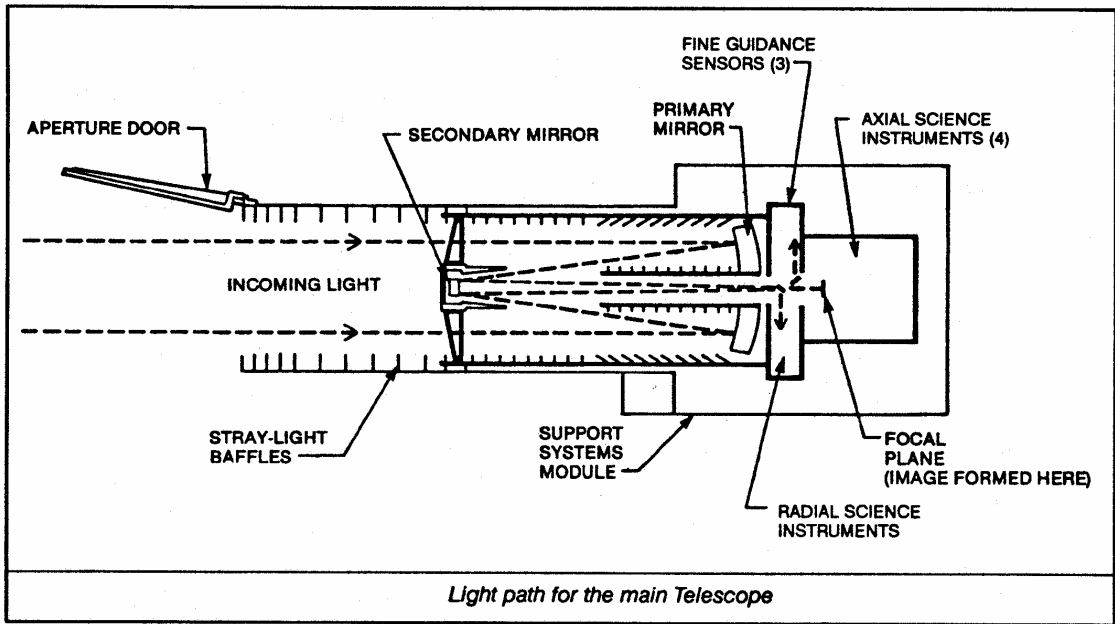

PRIMARY SERVICING TASKS

Gyroscope Pairs (Rate Sensing Units) and Electronics Control Unit

Three gyroscopes (or gyros) are required to point and track HST. Three more gyros are onboard as backups. The total of six gyros are packaged in pairs of two, called Rate Sensing Units (RSU). One gyro failed in December 1990; a second failed in June 1991 and a third in November 1992.

Two of these three gyros, one located in pair 2 and the other in pair 3, contain hybrid electronics that are suspected of causing the failures. Gyro pairs 1 and 3 also have experienced a failure in one channel of their Electronics Control Unit (ECU), the cause of which is suspected to be a random electronic part failure. While these failures have not affected HST's performance, replacing the failed hardware will increase system reliability.

The Rate Sensor Units are inside the housing of HST. To begin the replacement work, the spacewalking astronaut, standing in a foot restraint mounted on the end of the Shuttle's mechanical arm, will first back out several bolts to open doors covering the star tracker near the base of HST. One of the four bolts holding the doors, called the star tracker seal, must be completely removed to unlatch the doors.

A programmable power wrench will be used to loosen and tighten all bolts during the RSU replacement. While the arm-mounted astronaut unlatches the doors, his fellow spacewalker, mounted on a foot restraint attached to a support structure in the Shuttle's bay, will assist. Once the doors are unlatched, they will be swung open to provide access to the bay area.

The Rate Sensor Units are located behind the cone-shaped star tracker shades in the bay area of the telescope. To replace an RSU, these shades may have to be removed. If so, three bolts must be loosened and the shade pulled off. The shade then can be temporarily stowed outside the work area. The shades are reinstalled by pushing them back into place and then retightening the three bolts.

To remove an RSU, the spacewalker, standing in an Adjustable foot restraint attached to the telescope, will loosen three bolts and disconnect two electrical plugs. The RSU then may be removed by holding a handrail located at the top of the unit.

During these activities, the astronaut standing on the end of the arm will assist his partner from behind. The new RSU, carried aloft in an Orbital Replacement Unit Carrier (ORUC) in the Shuttle's bay, will be installed by sliding it into place and then retightening the three bolts and hooking up the two electrical plugs.

The time required to set up, remove two RSUs, install two RSUs and then clean up the area during training has been around 3.5 hours, including the possible removal and reinstallation of the star tracker shades.

Electronic Control Units

The Electronic Control Units are the electrical brains for the Rate Sensor Units and are located in a service bay on the Hubble Space Telescope. Once the compartment door is opened, two of the three ECUs will be replaced by removing four bolts and disconnecting each one's electrical cable. The new units, which are retrieved from a protective container in the payload bay, will be installed in a similar fashion.

Solar Array II

The Solar Arrays were built in Europe under the auspices of ESA. The solar arrays provide the telescope and its instruments with 5 kW of electrical power at the start of their lifetime. They constitute the spacecraft's two "wings" and consist of 50,000 silicon photoelectric cells, covering a surface area of 84 square yards/6.6 x 39.6 x 9.24 ft (70 square meters/2 x 12 x 2.8 m).

The arrays are the flexible "roll-out and roll-up" type and are made of huge sheets of plastic (fiberglass-reinforced Teflon) held in place by horizontal metal struts, which also unroll. Each wing weighs about 352 lbs. (160 kg).

But the arrays create a jitter that interferes with spacecraft stability and affects its pointing capability. The arrays now on Hubble were supposed to accommodate the expansion and contraction caused by heating and cooling as the space telescope moves in and out of daylight during its 96-minute orbits. However, a compensation device that allows for the expansion and contraction of the solar array blankets does not expand and contract as smoothly as expected.

As a temporary fix, engineers created software that commanded Hubble's pointing system to compensate for the jitter automatically. This procedure occupies a large portion of the on-board computer memory, though, and to truly fix the problem, the solar arrays must be replaced.

ESA redesigned and provided to NASA a set of spare solar arrays to reduce the jitter to an acceptable level. This set will be installed on the HST after the existing arrays are removed; the arrays now on the spacecraft will be returned to Earth. To significantly reduce jitter, the new arrays have thermal insulation sleeves on the array supports, called bi-stems, to minimize heating and cooling of the support during each orbit. Springs that work like shock absorbers also will take up tension at the array ends.

To replace the HST Solar Arrays, first the old arrays are retracted by commands from the Space Telescope Operations Control Center. Once they have been retracted and stowed, the arm-mounted spacewalker will release three latching points on the first array to be removed. Once the three latches have been released, the array can be removed and handled using a transfer handhold mounted to the array.

The array then is carried by having the mechanical arm moved to position the astronaut within reach of a temporary stowage bracket for the old arrays, mounted on the right-hand side of the Solar Array Carrier in Endeavour's cargo bay. While being moved from place to place at the end of the arm, the crew member also may evaluate the handling characteristics of the array to prepare for carrying the new array up to its installation position. Throughout the removal operation, the arm-mounted astronaut will be assisted by his counterpart, who will be moving about via handholds on the telescope and Shuttle.

The new solar array is removed from the SAC by disconnecting a power and a data connection and then unlatching three latch points exactly like the latch points on the telescope. A temporary transfer handle allows the arm-mounted astronaut to carry the new array up to the installation location. His counterpart will assist with the installation by standing in a foot restraint mounted to the telescope near the work area.

While the array is being transported, the power and data connectors are secured in temporary holding brackets on the array. To install the new array, first it is moved into position and once seated, the three latch points are locked in place and the connectors plugged in. The second array is removed and its replacement installed in exactly the same fashion.

During training, the time required to perform a changeout of the solar arrays was about 5 hours, and one full spacewalk is dedicated to this task. The new arrays are not planned to be deployed during the spacewalk performed to install them.

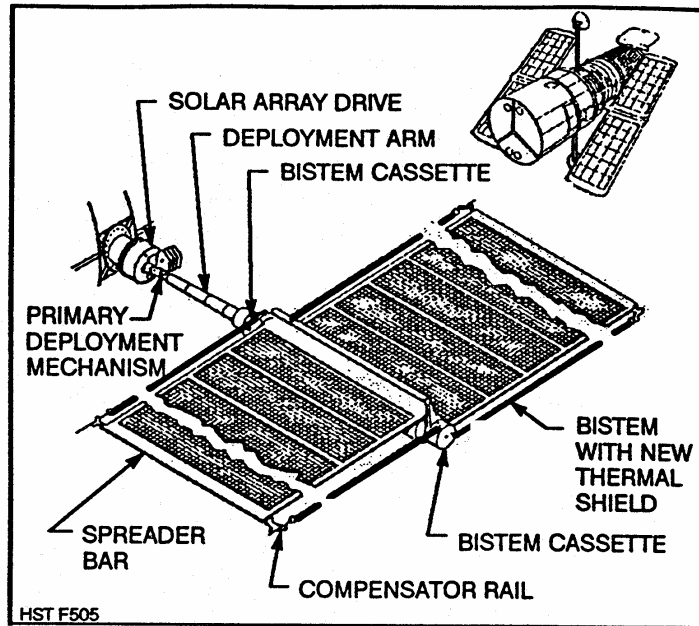

SOLAR ARRAY WING DETAIL

SOLAR ARRAY CARRIER (SAC)

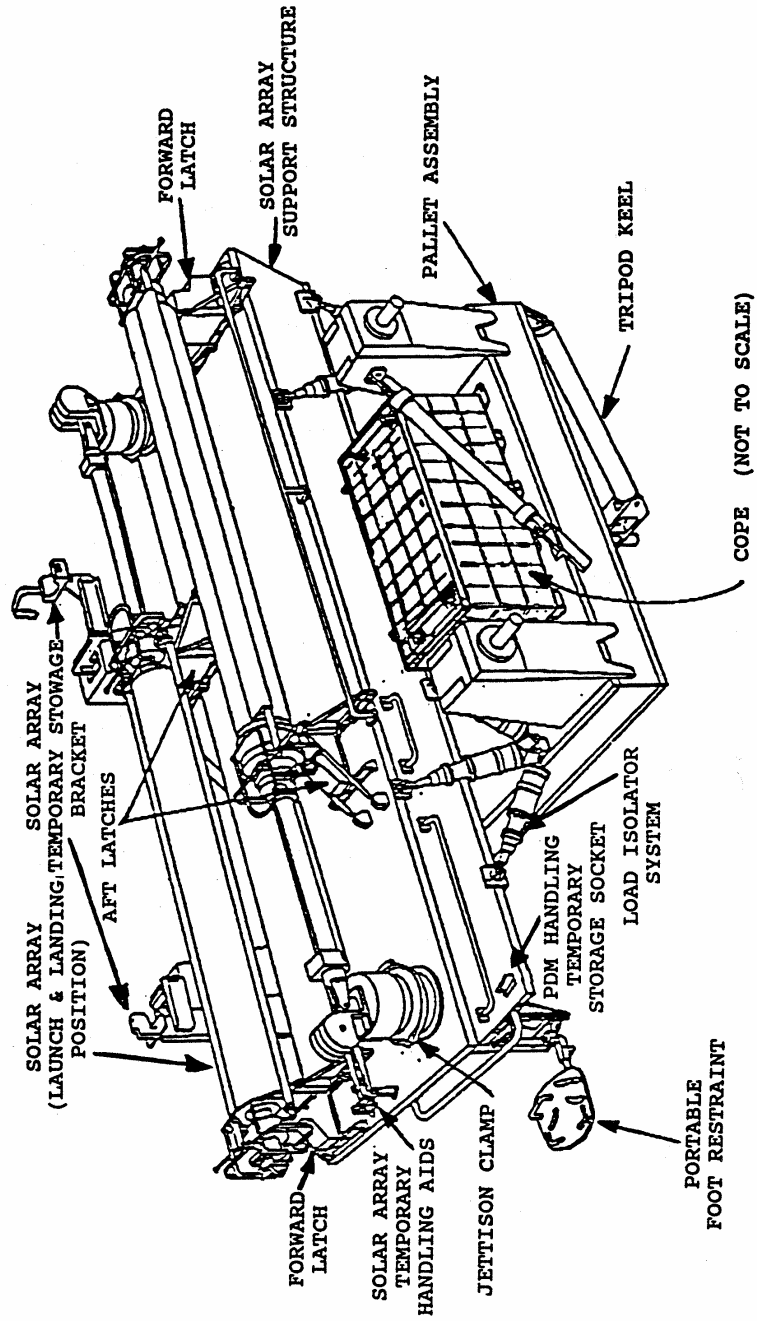

Wide Field/Planetary Camera-II (WF/PC-II)

The current WF/PC has been used to study bright, high-contrast objects, such as major solar system planets and nearby star clusters and galaxies. Spherical aberration, however, has hampered the ability of the camera to provide high-resolution images of the very faintest objects, or objects in a field crowded with other objects.

The WF/PC-II is a spare instrument developed, beginning in 1985, by the Jet Propulsion Laboratory (JPL) team, Pasadena, Calif., that built the first WFPC. When Hubble's mirror was found to be flawed, NASA and the WFPC science team immediately began working on an optical correction that could be built into WFPC2. The new design incorporates an optical correction by the refiguring of relay mirrors already in the optical train of the cameras. Each relay mirror is polished to a new prescription that will compensate for the incorrect figure on HST's primary mirror. Small actuators will fine-tune the positioning of these mirrors on orbit, ensuring the very precise alignment that is required.

Through a servicing bay door built into the side of HST, astronauts will slide out the 610-pound (277-kilogram), wedge-shaped WFPC, as they would a giant drawer, and replace it with WFPC2. The removed WFPC will be returned to Earth.

The WFPC2 will have three wide-field cameras and one planetary camera instead of the original total of eight. The WFPC2 team chose to reduce the number of cameras to four in order to develop a system to align the corrective relay mirrors on-orbit. Improved Charged Coupled Devices (CCDs) are incorporated into WFPC2 to improve its sensitivity, particularly in the ultraviolet.

To remove and replace the Wide Field/Planetary Camera (WF/PC), the doors to the service bay at the base of the telescope are opened and specially designed guide rails are installed to assist with removal of the instrument.

A temporary handhold then is installed on the WF/PC. Using this handhold, the arm-mounted spacewalker pulls the WF/PC out of its installed position while his counterpart watches the alignment of the WF/PC on the rails and ensures it is level as it is removed. Once removed from the telescope cavity, the arm-mounted astronaut is positioned within reach of a temporary parking fixture for the old WF/PC in Endeavour's cargo bay, where it is stowed.

A temporary handhold is installed on the new unit, WF/PC-II, in its Scientific Instrument Protective Enclosure (SIPE) in Endeavour's cargo bay. The WF/PC-II is pulled from the SIPE by the arm-mounted crew member, who is later moved to the installation site by the arm operator. Meanwhile, the SIPE door is temporarily latched by his crew mate.

Before sliding the WF/PC-II into place inside the telescope, a cover over its mirror is removed. Then, the arm-mounted spacewalker slides it into the telescope slot while his fellow spacewalker checks to ensure that it is aligned on the guide rails. Once inserted in place, the handhold is removed from the instrument and the guide rails are detached.

Finally, the old WF/PC is removed from its temporarily stowed position in the parking fixture and inserted into the SIPE that carried WF/PC-II, where it is secured for Endeavour's trip home.

Removal of the old WF/PC and the installation of WF/PC-II has taken about 4 hours and 15 minutes during training.

SOLAR ARRAY CARRIER (SAC)

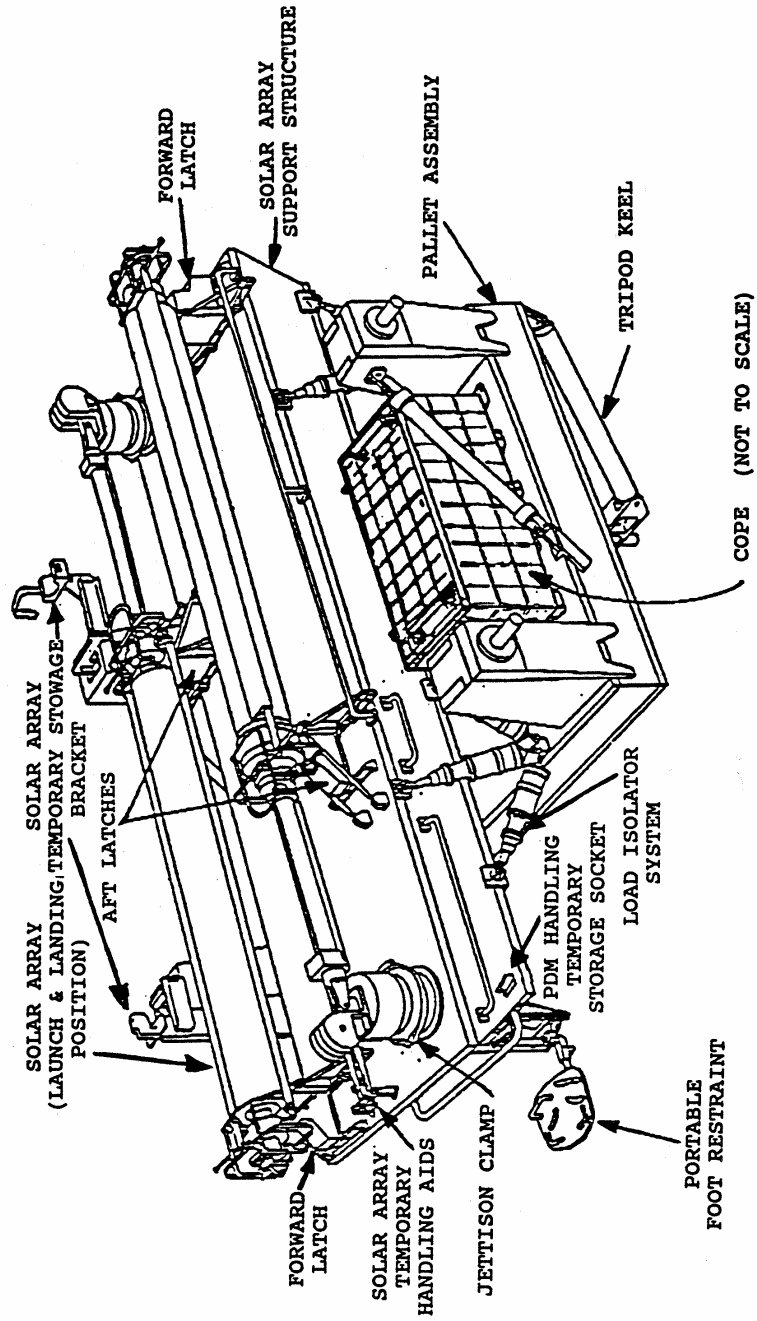

Corrective Optics Space Telescope Axial Replacement (COSTAR)

COSTAR is designed to optically correct the effects of the primary mirror aberration on three instruments besides the WFPC: the Faint Object Camera (FOC), the Faint Object Spectrograph (FOS) and the Goddard High Resolution Spectrograph (GHRS).

The FOC, provided by ESA, is designed to detect very low-luminosity celestial bodies and to provide the most detailed images on HST. It consists of an electronic conventional scanning camera (of the television type), whose front part is a powerful image intensifier tube. Its performance has been degraded by the spherical aberration, but the sharp image cores still allow the camera to detect details not seen by ground-based telescopes.

The FOS analyses the light from very faint objects in the visible and ultraviolet spectral regions. While the faintest objects now cannot be reached, observations of brighter sources are only moderately degraded.

The GHRS is intended for very detailed analysis of ultraviolet radiation. The instrument now loses spectral resolution on the faintest objects, but observations of brighter sources are only moderately degraded.

COSTAR was invented by the Hubble Space Telescope Strategy Panel, a group of scientists and engineers brought together at the Space Telescope Science Institute, Baltimore, Md., in the fall of 1990 to consider how to fix HST. Built by Ball Aerospace, Boulder, Colo., under contract to NASA, COSTAR has no detectors or cameras. It will use precisely shaped mirrors, ranging from about the size of a dime to a quarter, to correct for the spherical aberration.

Through a servicing bay door, astronauts will pull out the 487-pound (221-kilogram), phone booth-size High Speed Photometer (HSP) and install in its place the identically sized COSTAR. Once in place, COSTAR will deploy a set of mechanical arms, no longer than a human hand, that will place corrective mirrors in front of the openings that admit light into the Faint Object Camera, the Faint Object Spectrograph and the Goddard High Resolution Spectrograph. COSTAR's corrective mirrors will refocus light relayed by HST's primary mirror before it enters these three instruments. COSTAR will restore the optical performance of these instruments very close to the original expectations.

To install COSTAR, the spacewalkers first will open doors to the bay, that enclosed the HSP, by loosening several bolts. Once the doors are open, latches that hold the HSP in place will be loosened and then four electrical connectors and a ground strap will be disconnected from the instrument.

Then the HSP is lowered from its position to guide rails for the unit. The arm-mounted spacewalker and his crew mate, standing in a foot restraint attached to the telescope, will coordinate efforts to remove the device. The arm-mounted crew member will slide HSP out while his fellow spacewalker ensures that it is aligned with the guide rails.

Once removed, the HSP is held by the crew member standing on the end of the arm while the arm is positioned so the HSP can be placed in a temporary parking fixture mounted in the cargo bay. After it is temporarily stowed, a handhold is attached to COSTAR and it is lifted from its protective enclosure. A ground strap is disconnected and, while the arm-mounted astronaut is lifting COSTAR out, his crew mate is assisting by ensuring COSTAR is squarely aligned with the enclosure as it is extracted.

The arm-mounted crew member then is positioned up to the installation area while his fellow spacewalker moves to the site via handrails on the telescope. COSTAR then is aligned with the guide rails, with the arm-mounted spacewalker watching the alignment of a rail at the upper left-hand corner of COSTAR and his counterpart checking the alignment of a rail at the lower right corner.

Once COSTAR slides into place, the four electrical connections, disconnected from HSP, are connected to COSTAR along with the grounding strap, and the latches are tightened to hold COSTAR in place.

In training, removal of the HSP and installation of COSTAR has taken about 3 hours and 15 minutes.

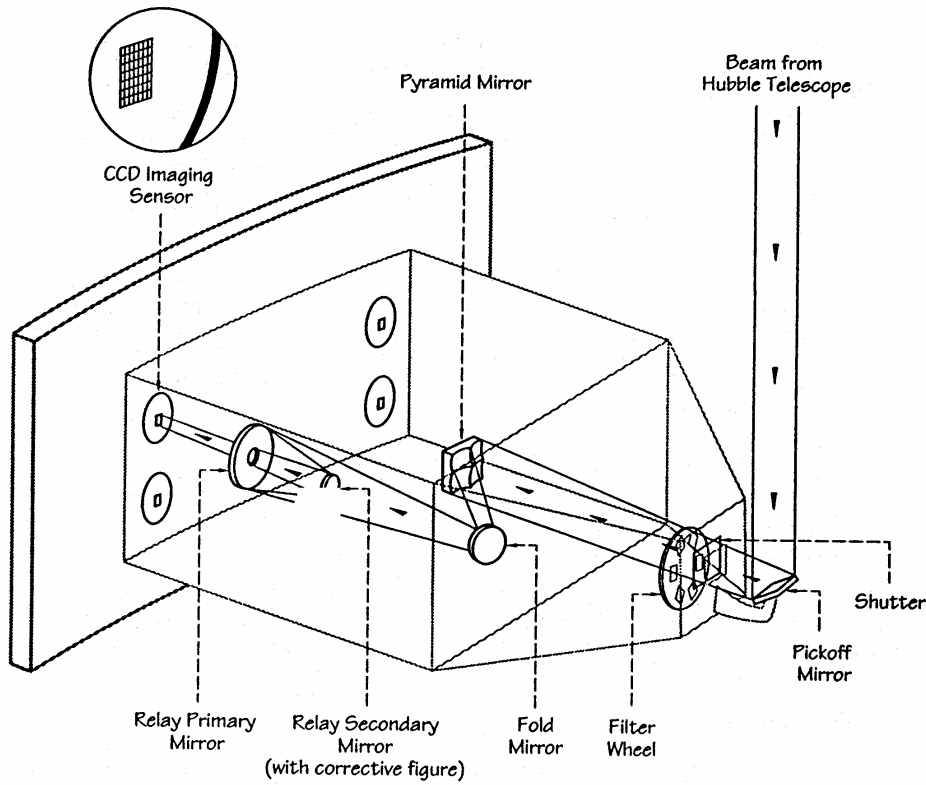

**WIDE FIELD/PLANETARY CAMERA-II
(WF/PC-II)**

(Only 1 of 4 light trains is illustrated)

Solar Array Drive Electronics 1 (SADE)

Each solar array wing has an electronics control assembly that includes a drive electronics unit. These units transmit positioning commands to the wing assembly. One of these Solar Array Drive Electronics units has failed due to transistor overheating. A replacement SADE, provided by ESA, will restore that lost capability and provide better heat protection for the transistors.

The Solar Array Drive Electronics are mounted on the inner side of one of the doors to an HST service bay. Two electronics boxes are mounted on the inside of the door, but only one is being replaced. Once the door is opened, the two spacewalkers - one mounted on the arm and one holding handrails on the telescope - will loosen six bolts to free the old SADE unit and disconnect electrical connectors attached to the unit. The new SADE unit is installed in the reverse of this process.

Magnetometer System 1

The HST's two magnetometers (also known as magnetic sensing systems) measure the spacecraft's relative orientation with respect to the Earth's magnetic field. Neither magnetometer is functioning at full capability. Both replacements have improved electronics and thermal blankets added. The replacement magnetometers will be snapped into place over the existing magnetometers, which will not be removed from the HST.

Both of the magnetic sensing systems are located near the top of the telescope near the aperture door. The new units will be installed using four rotating knob connectors and will be attached directly on top of the old units by removing some insulation and removing and reinstalling the electrical cable. These units are used to help measure the observatory's position relative to Earth's magnetic field.

Fuse Plugs

Fuses for both the gyros and instruments will be replaced to correct sizing and wiring discrepancies.

The fuses that will be replaced on the HST are located on the inside of a compartment door. Eight of the fuse plugs will be removed and replaced by the spacewalking astronauts. Once all have been replaced, checks will be made to ensure they are working properly.

SECONDARY SERVICING TASKS

Co-Processor

The DF-224 is the HST's flight systems computer. One of the computer's six memory units has failed and another has partially failed. Hubble requires only three memory units to fully function, so the failures have not affected telescope operations. However, to restore the memory redundancy and augment the telescope's memory capacity and speed, a co-processor, based on 386-computer architecture, will be integrated into the flight systems computer, which will increase both flight computer memory and the speed of some operations.

The DF-224 co-processor will be installed on top of the HST computer located in a compartment on the telescope. The memory upgrade is installed using handles on the computer and attaching four bolts using a power tool.

Goddard High Resolution Spectrograph Redundancy Kit

The GHRS has two detector systems. Because of the anomalous behavior of a low-voltage power supply, the side-one detector no longer is used. The redundancy kit consists of an externally mounted relay box that enhances system redundancy so that the side-one detector can be used and the side-two detectors will not be compromised if the anomaly recurs.

Made up of four cables and a relay box, the Goddard High Resolution Spectrograph redundancy kit is designed to bypass an erratic detector system on the science instrument located in an instrument bay on the lower portion of the HST. The relay box is installed first using a power tool similar to an electric drill. This is followed by attachment of the four cables.

HUBBLE SPACE TELESCOPE TOOLS AND CREW AIDS

The crew of STS-61 has more than 200 tools and crew aids with them for the servicing of the Hubble Space Telescope. The tools and crew aids, known as Space Support Equipment (SSE) hardware, range from a simple bag for carrying some of the smaller tools to sophisticated, battery operated power equipment. These tools will be used by the EVA crew members servicing the spacecraft.

Crew Aids

Crew aids are defined as those that are fixed in place and those that are portable equipment items but not hand tools, used to assist crew members in accomplishing servicing mission tasks. SSE equipment crew aids permit the crew members to maneuver safely or to restrain themselves, transfer Orbital Replacement Units (ORUs) and other portable items, protect equipment and themselves during changeout activities and temporarily stow or tether equipment during EVAs.

Examples of crew aids are handrails, handholds, translation devices, transfer equipment, protective covers, tethering devices, grapple fixtures, foot restraint sockets and stowage and parking fixtures.

Tools

Tools are hand-operated or manipulated devices that allow the EVA astronauts to increase the efficiency of performing intricate, labor-intensive tasks.

Stowage

The tools and crew aids will be stowed on or in the Solar Array Carrier (SAC), Orbital Replacement Unit Carrier (ORUC), Flight Support System (FSS), HST Tool Box, Sidewall-mounted adapter plates, Provisions Stowage Assembly (PSA), an Adaptive Payload Carrier (APC), middeck lockers, aft flight-deck and airlock. Tools and crew aids are provided by Johnson Space Center, Houston, and Goddard Space Flight Center, Greenbelt, Md.

Uses

Tools and crew aids considered "general," with a wide variety of uses, include the Power Ratchet Tool (PRT), Multi-setting Torque Limiter (MTL), Adjustable extension with 7/16th-inch sockets, ingress aids, portable work- light receptacle and a locking connector tool. More specific, but still considered general, items are a low-gain antenna (LGA) cover, umbilical connector covers, a flight support system (FSS), berthing and positioning system (BAPS), support post and a multi-layer insulation (MLI) repair kit. To be used on the changeout of the Wide Field Planetary Camera 2 (WFPC2) are the WFPC handholds, WFPC guide studs, quick-release zip nuts, WFPC pick-off mirror cover, forward fixture, aft fixture and the HST radial bay cover.

For the High Speed Photometer (HSP) replacement with the Corrective Optics Space Telescope Axial Replacement (COSTAR), tools and aids to be used will be the COSTAR contamination cover, a COSTAR handling aid, an HSP handling aid, forward fixture, aft fixture and an axial Science Instrument Protective Enclosure (SIPE) safety bar.

For the solar array replacement, the astronauts will use articulating foot restraints, solar array primary drive mechanism handles, solar array temporary stowage brackets (TSBs), solar array transfer handles, solar array jettison handle, solar array spines, Portable Flight Release Grapple Fixture (PFRGF) and a Marmon clamp.

For the changeout of the gyro rate sensor units, crew members will use a Portable Foot Restraint (PFR) socket converter (90-degree), Fixed-Head Star Tracker (FHST) light shade covers and a FHST delta plate cover.

Portable Foot Restraint

There are two Hubble Space Telescope portable foot restraints built for use on the STS-61 mission. These restraints are used by the spacewalking astronauts during the five extravehicular activities to provide a stable platform from which to work. Both restraints are stowed in the payload bay, one on the left side and the other on the flight support system.

Tool Box

The HST tool box is designed to stow individual tools, tool boards and tool caddies that will be used throughout the mission. The box is mounted on the right side of the payload bay. Each tool inside the box is stowed in a specific location with markings to assist the astronauts in the retrieval and stowage.

Power Ratchet Tool (PRT)

The Goddard-provided power ratchet tool (PRT) is powered by a 28-volt battery. Made of titanium and aluminum, the 17-inch (43-centimeter) tool will be used for tasks requiring controlled torque, speed or turns and can be used where right-angle access is required. It will provide 25 foot-pounds of pressure in the motorized mode and 75 foot-pounds of pressure in the manual mode. It has a speed of 10 to 30 revolutions per minute. A spare power ratchet will be carried on the mission, as will spares for all other tools to be used by the astronauts.

HST Power Tool

This tool is a modified, battery-operated power tool with torque and rpm control. The design includes a 3/8-inch drive fitting, forward and reverse drive rotation, torque ranges from 50 to 300 inch-pounds and a bracket for mounting the tool to the spacesuit.

Mini-Power Tool

The mini-power tool is a battery-operated screwdriver intended for use when a larger power tool is not required and when work space is limited. It can be used as a power tool or with the power off, the output shaft is locked automatically for use as a manual driver.

Multisetting Torque Limiter

This tool is provided to prevent damage to hardware due to the application of torque which may exceed the design limits. Multisetting torque limiters are used in conjunction with the power tools or hand tools that interface with bolts and latches on the telescope.

Adjustable Extensions

Several extensions were designed to be Adjustable to ease the movement of the astronauts while reducing the time required for tool changeouts. The Adjustable extensions replace several fixed length extensions by providing Adjustment from 12 to 16.5 inches. Another Adjustable extension provides lengths from 15 to 24 inches. When retracted, these extensions reduce the potential for damage to other hardware.

CORRECTIVE OPTICS SPACE TELESCOPE AXIAL REPLACEMENT (COSTAR)

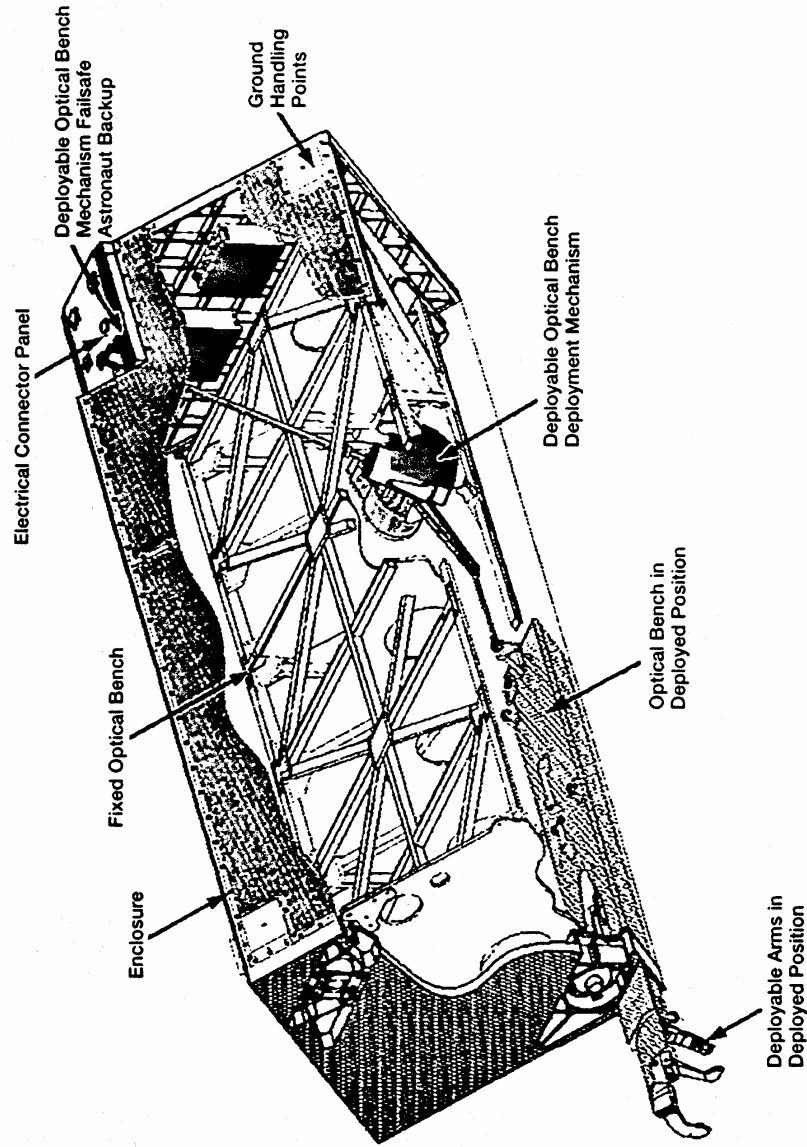

ORBITAL REPLACEMENT UNIT CARRIER (ORUC)

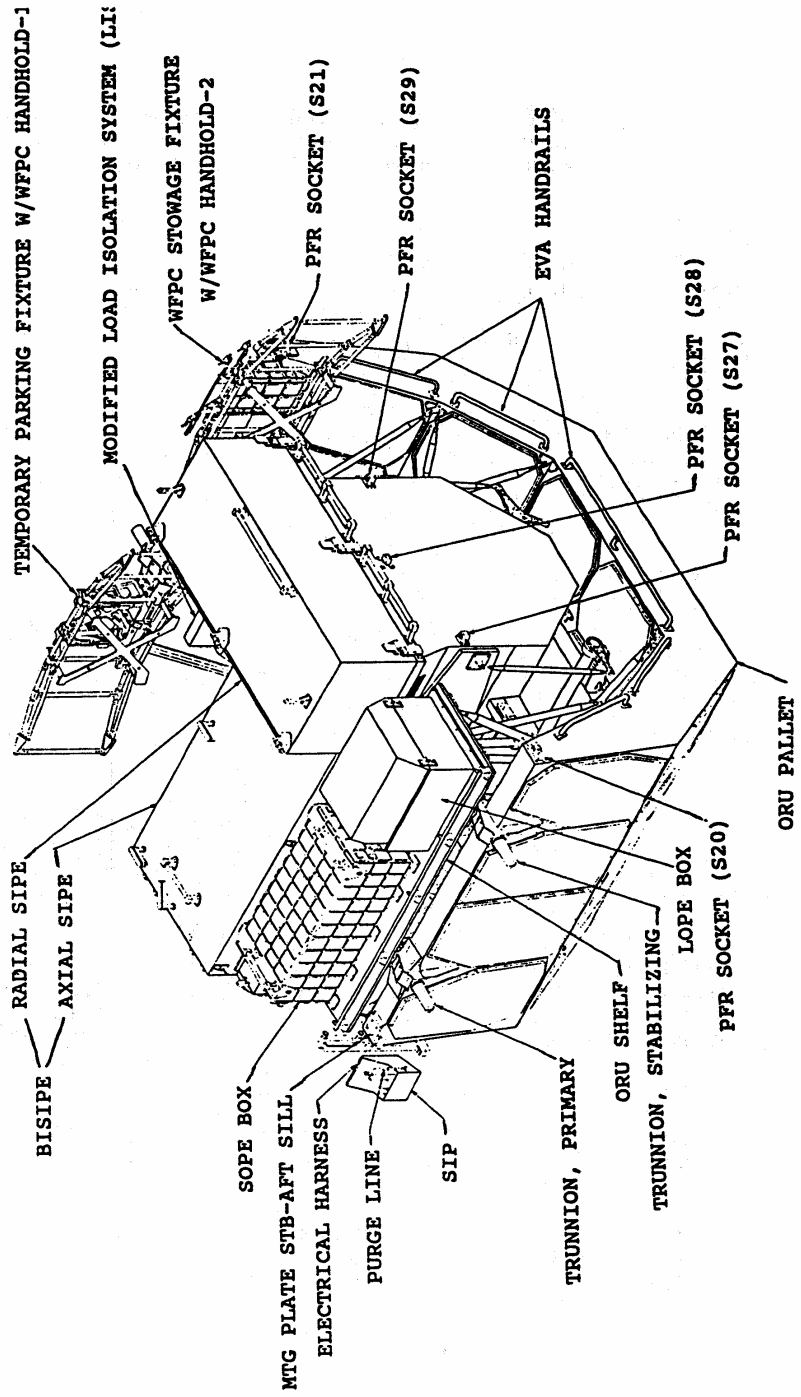

FLIGHT SUPPORT SYSTEM (FSS)

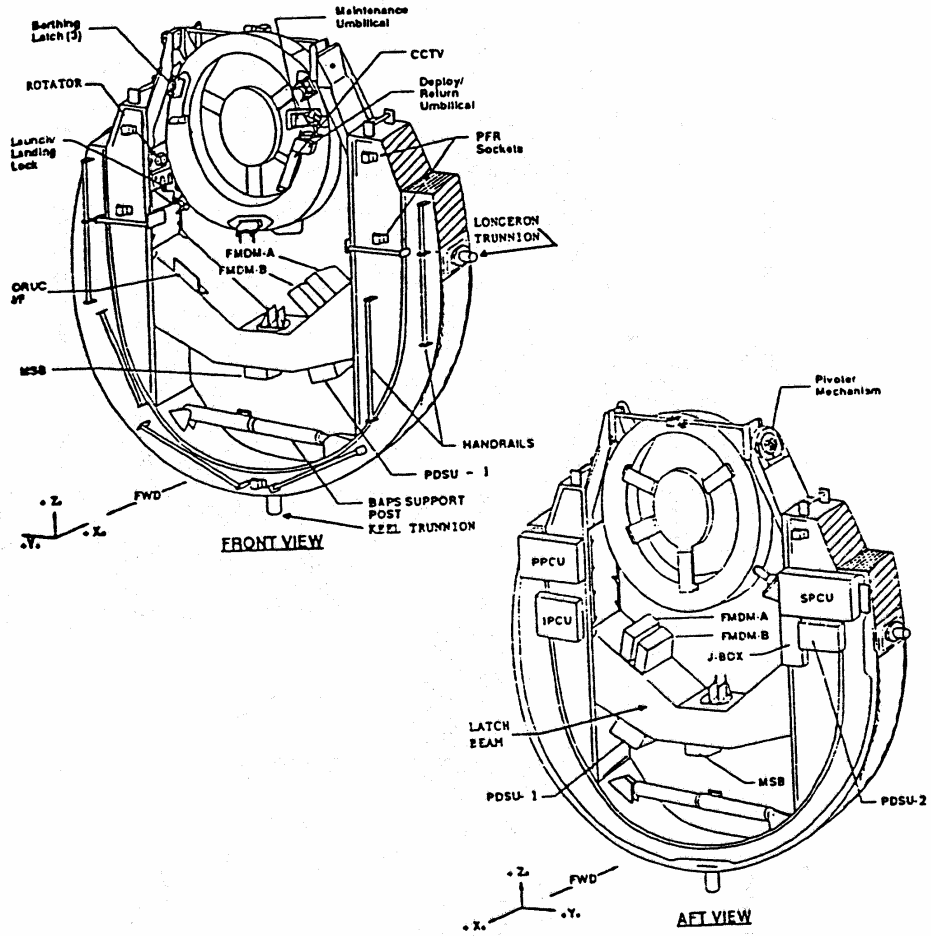

HST TOOL BOX

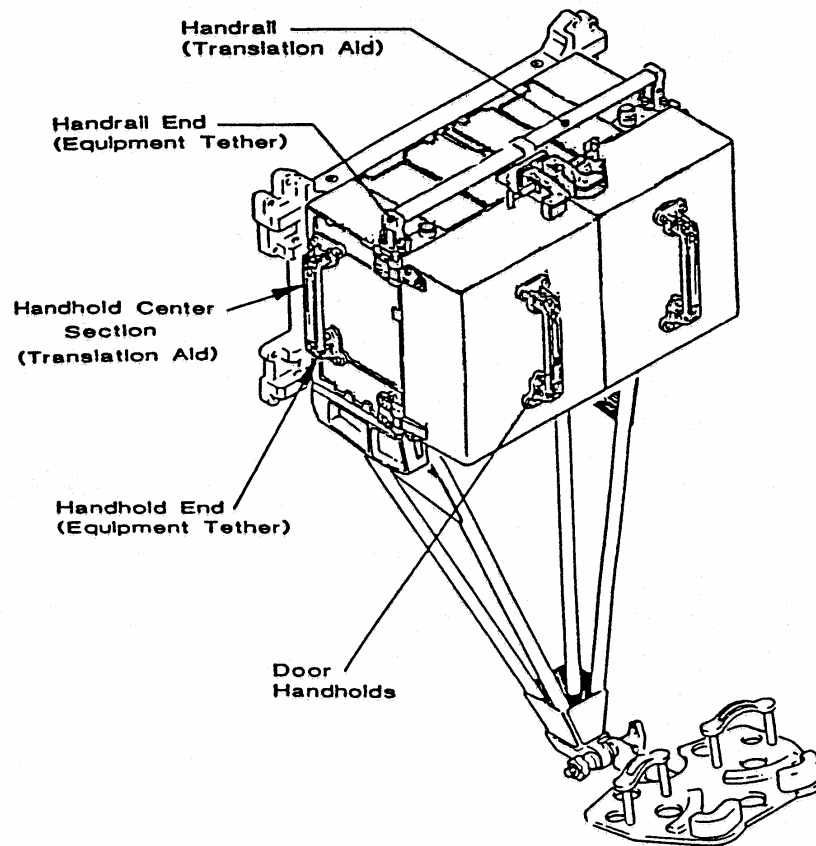

BERTHING AND POSITIONING SYSTEM (BAPS)

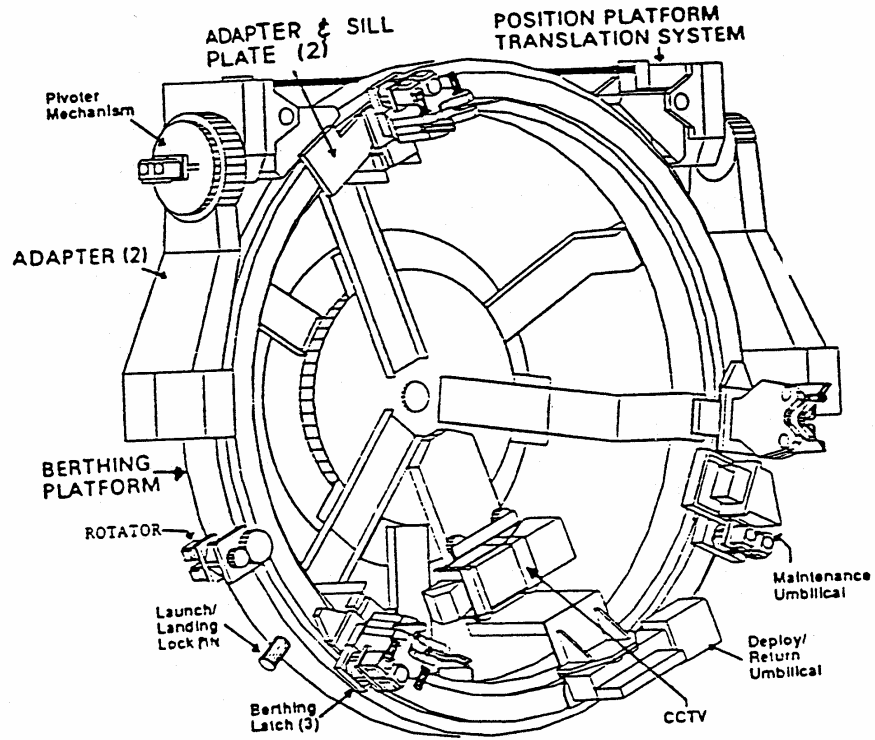

ICBO

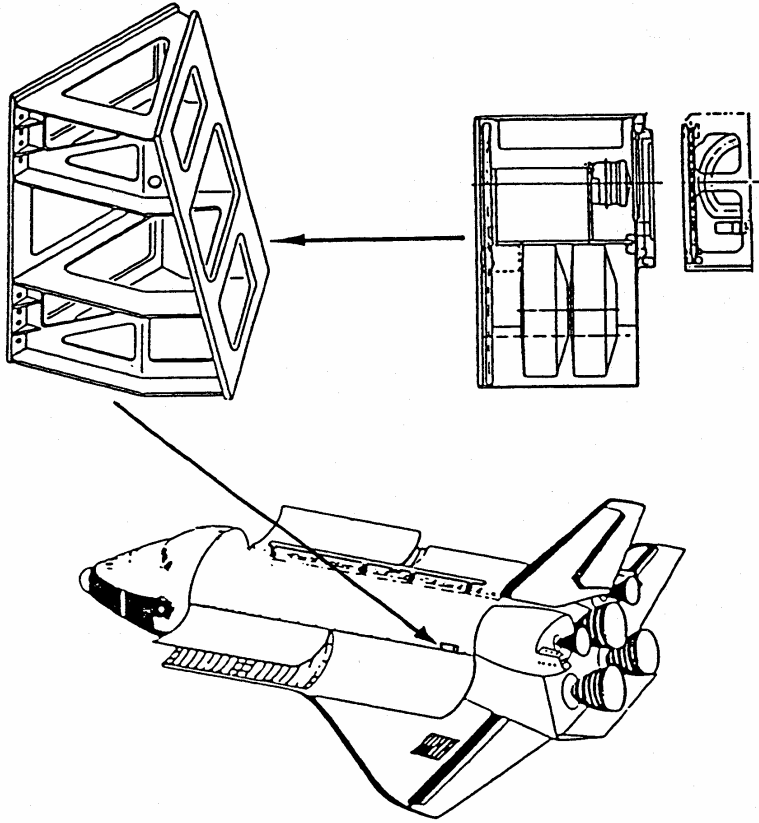

The payload configuration

IMAX

THE IMAX project is a collaboration between NASA and the Smithsonian Institution's National Air and Space Museum to document significant space activities using the IMAX film medium. This system, developed by IMAX Systems, Corp., Toronto, Canada, uses specially designed 70 mm film cameras and projectors to record and display very high definition large- screen pictures.

An IMAX camera system will be flown on Shuttle Mission STS-61 and will be used by Endeavour's crew to collect material for upcoming IMAX productions. IMAX cameras have flown on several Shuttle missions and film from those missions was used to form the IMAX productions The Dream is Alive and The Blue Planet.

In-Cabin IMAX Camera Equipment

The IMAX system consists of a camera, lenses, rolls of film, two magazines with film, an emergency speed control, a Sony recorder and associated equipment, two photographic lights, supporting hardware in the form of mounting brackets to accommodate the mode of use, two cables and various supplemental equipment.

The IMAX and supporting equipment are stowed in the middeck for in- cabin use. The IMAX uses two film magazines which can be interchanged as part of the operation. Each magazine runs for approximately 3 minutes. When both magazines are consumed, reloading of the magazines from the stowed supply of film is required. Lenses are interchanged based on scene requirements. The IMAX will be installed in the orbiter middeck approximately 7 days prior to launch.

IMAX Cargo Bay Camera (ICBC)

During Shuttle Mission STS-61, an IMAX Cargo Bay Camera (ICBC) will be carried in the payload bay of Endeavour and used to document activities associated with the servicing of the Hubble Space Telescope. The camera is mounted in a pressure sealed container with a viewing window. The window has a sliding door which opens when the camera is in operation. The camera is controlled from the aft-flight deck, exposing the film through a 30 mm fisheye lens.

AIR FORCE MAUI OPTICAL SYSTEM

The Air Force Maui Optical System (AMOS) is an electrical-optical facility on the Hawaiian island of Maui. No hardware is required aboard Discovery to support the experimental observations. The AMOS facility tracks the orbiter as it flies over the area and records signatures from thruster firings, water dumps or the phenomena of "Shuttle glow," a well-documented fluorescent effect created as the Shuttle interacts with atomic oxygen in Earth orbit. The information obtained by AMOS is used to calibrate the infrared and optical sensors at the facility.

DTO-667: PILOT INFLIGHT LANDING OPERATIONS TRAINER (PILOT)

One of the challenges to flying long duration Shuttle missions is the issue of orbiter landing tasks requiring a high level of skill and proficiency yet data showing that a pilot's landing skills degrade after an extended absence from a landing trainer such as the Shuttle Training Aircraft. During Shuttle Mission STS-61, a portable scientific workstation designed to aid the Shuttle commander and pilot in maintaining those landing skills will be demonstrated for the second time.

The PILOT system hardware, which flew on Shuttle Mission STS-58 in October 1993, consists of a portable scientific workstation, a high resolution color display and a hand controller with orbiter look and feel. The software used in the system was transferred from the Shuttle Engineering Simulator software which is used to validate Shuttle flight software. This provides PILOT with orbiter handling and guidance characteristics.

The PILOT system is stowed in lockers on the flight deck and middeck areas of the Space Shuttle. When a member of the crew wants to use the system, the workstation is mounted on a console directly in front of the pilot's seat on the flight deck and the PILOT system hand controller is attached to the orbiter's hand controller.

In addition to evaluating the ability to maintain landing skills of a Shuttle crew in Earth-orbit, the PILOT system may be integrated into the standard training activities of all Shuttle crews at the Johnson Space Center in Houston.

STS-61 CREWMEMBERS



STS061-S-002 -- STS-61 crew portrait. Left to right (seated) are astronauts Kenneth D. Bowersox, pilot; Kathryn C. Thornton, F. Story Musgrave, and Claude Nicollier, all mission specialists. Left to right (standing) are astronauts Richard O. Covey, mission commander; Jeffrey A. Hoffman and Thomas D. Akers, mission specialists. On the left side of the table is a model of the Hubble Space Telescope, on the right a model of the Space Shuttle. In the middle is the STS-61 insignia.

No copyright is asserted for this photograph. If a recognizable person appears in the photo, use for commercial purposes may infringe a right of privacy or publicity. It may not be used to state or imply the endorsement by NASA or by any NASA employee of a commercial product, process or service, or used in any other manner that might mislead. Accordingly, it is requested that if this photograph is used in advertising and other commercial promotion, layout and copy be submitted to NASA prior to release.

PHOTO CREDIT: NASA or National Aeronautics and Space Administration.

BIOGRAPHICAL DATA

RICHARD O. COVEY, 47, Col., USAF, is Commander (CDR) of STS-61. Selected as an astronaut in January 1978, Covey considers Fort Walton Beach, Fla., his hometown and will be making his fourth space flight.

Covey graduated from Choctawhatchee High School, Shalimar, Fla., in 1964; received a bachelor of science degree in engineering sciences with a major in astronautical engineering from the U.S. Air Force Academy in 1968, and a master of science degree in aeronautics and astronautics from Purdue University in 1969.

Covey first flew as Pilot for Shuttle mission STS 51-I in August 1985. He next flew as Pilot on STS-26 in September 1988. On his most recent flight, he was Commander for STS-38 in November 1990. Covey has logged over 385 hours in space.

KENNETH D. BOWERSOX, 37, Cmdr., USN, will serve as Pilot (PLT). Selected as an astronaut in June 1987, Bowersox was born in Portsmouth, Va., but considers Bedford, Ind., his hometown and will be making his second space flight.

Bowersox graduated from Bedford High School, Bedford, Ind.; received a bachelor's degree in aerospace engineering from the Naval Academy in 1978 and a master of science degree in mechanical engineering from Columbia University in 1979.

Bowersox first flew as Pilot for Shuttle mission STS-50 in June 1992. He has logged over 331 hours in space.

TOM AKERS, 42, Lt. Col., USAF, will serve as Mission Specialist 5 (MS5) and as one of the extravehicular activity crew members. Selected as an astronaut in June 1987, Akers was born in St. Louis, Mo., but considers Eminence, Mo., his hometown and will be making his third space flight.

He graduated from Eminence High School and received bachelor and master of science degrees in applied mathematics from the University of Missouri-Rolla in 1973 and 1975, respectively.

Akers served as a mission specialist on STS-41 in October 1990. His next flight was as a mission specialist on STS-49 in May 1992. Akers was one of the EVA crew members of a three-person spacewalking team that successfully captured the stranded International Telecommunications Satellite. He also performed a second EVA on STS-49 to evaluate space station construction techniques. He has logged over 311 hours of space flight.

JEFFREY A. HOFFMAN, 49, will be Mission Specialist 3 (MS3) and serve as one of the extravehicular activity crew members. Selected as an astronaut in January 1978, Hoffman considers Scarsdale, N.Y., his hometown and will be making his fourth space flight.

Hoffman graduated from Scarsdale High School, received a bachelor's degree in astronomy from Amherst College, received a doctorate in astrophysics from Harvard University and received a master's degree in materials science from Rice University.

Hoffman first flew on STS-51D in April 1985, a mission during which he performed a spacewalk in an attempt to rescue a malfunctioning satellite. He next flew on STS-35 in December 1990. Hoffman made his third space flight as Payload Commander and mission specialist on STS-46 in July 1992.

BIOGRAPHICAL DATA

F. STORY MUSGRAVE, 58, will be Mission Specialist 4 (MS4). He also will serve as Payload Commander and as a member of the extravehicular activity team. Selected as an astronaut in August 1967, Musgrave considers Lexington, Ky., his hometown and will be making his fifth space flight.

Musgrave graduated from St. Mark's School, Southborough, Mass., in 1953; received a bachelor's degree in mathematics and statistics from Syracuse University in 1958; received a master's degree in operations analysis and computer programming from the University of California at Los Angeles in 1959; received a bachelor's degree in chemistry from Marietta College in 1960; received a doctorate in medicine from Columbia University in 1964; received a master's degree in physiology and biophysics from the University of Kentucky in 1966 and received a master's degree in literature from the University of Houston in 1987.

Musgrave flew as a mission specialist on STS-6 in April 1983, on Spacelab-2 in August 1985 and on STS-33 in November 1989. More recently, he served aboard Space Shuttle Atlantis, STS-44 in November 1991. He has logged more than 598 hours in space.

CLAUDE NICOLLIER, 49, will be Mission Specialist 2 (MS2). Under an agreement with the European Space Agency and NASA, he was selected as an astronaut in 1980. Nicollier was born in Vevey, Switzerland, and will be making his second space flight.

Nicollier graduated from Gymnase de Lausanne, Lausanne, Switzerland, received a bachelor's degree in physics from the University of Lausanne and received a master's degree in astrophysics from the University of Geneva. Nicollier first flew as a mission specialist on STS-46 in July 1992 and has logged more than 191 hours in space.

KATHRYN C. THORNTON, 41, will serve as Mission Specialist 1 (MS1) and as one of the extravehicular activity crew members. Selected as an astronaut in May 1984, Thornton was born in Montgomery, Ala., and will be making her third space flight.

Thornton received a bachelor of science degree in physics from Auburn University and a master of science degree and a doctorate in physics from the University of Virginia. Thornton was awarded a NATO postdoctoral fellowship to continue her research at the Max Planck Institute of Nuclear Physics in Heidelberg, Germany.

Thornton first flew as a mission specialist on STS-33 in November 1989. On her second flight, she served on the crew of STS-49 in May 1992. On STS-49, Thornton performed an extravehicular activity to evaluate space station assembly techniques. She has logged over 333 hours in space.

STS-61 ACRONYMS AND ABBREVIATIONS

A-h	ampere-hour
ac	alternating current
ACE	actuator control electronics
ACP	astronaut control panel
AD	aperture door
AFD	aft flight deck
APS	antenna pointing system
AS	aft shroud
ATM	Apollo Telescope Mount
BAPS	berthing and positioning system
BCU	bus coupler unit
BOD	bright object detector
BOL	beginning of life
BOT	beginning of travel
BPRC	battery protection and reconditioning circuit
bps	bits per second
BPRC	battery protection and reconditioning circuit
BPSK	biphase shift keyed
BREC	body rate error check
C&DH	communication and data handling
C/C	configuration control
CC	cargo control
CCC	charge current controller
CCTV	closed-circuit television
CDI	command and data interface
CDU	command detector unit
CFRP	carbon-fiber-reinforced plastic
CGG	contingency gravity gradient
CIF	computer interface
CMD	command module
COM	communications module
CORU	candidate orbital replacement unit
CPM	central processor module
CPU	central processing unit
CSM	cargo systems manual
CSS	coarse Sun sensor
CU/SDF	control unit/science data formatter
D/A	digital to analog
DAK	double-aluminized Kapton
DBA	diode box assembly
dc	direct current
DCE	deployment control electronics
DIH	discrete input high
DISP	display
DIU	data interface unit
DIUI	DIU interface module
DMS	data management subsystem
DMU	data management unit
DPC	direct power converter

ECA	electronics control assembly
ECU	electronics control unit
ED	engineering data
EDB	external data bus
EMI	electromagnetic interference
EOL	end of life
EOT	end of travel
EP/TCE	electrical power/thermal control electronics
EPS	electrical power subsystem
ES	equipment section
ESA	European Space Agency
ESTR	engineering/science tape recorders
EU	electronics unit or expander unit
EVA	extravehicular activity
FEP	fluorinated ethylene-propylene
FGE	fine guidance electronics
FGS	fine guidance sensor
FHST	fixed head star tracker
FHSTI	FHST interface
FIFO	first in first out
FMDM	flexible multiplexer/demultiplexer
FOC	faint object camera
FOD	Flight Operations Directorate
FOS	faint object spectrograph
FOV	field-of-view
F/S	filter/shaper
FPA	focal plane assembly
FPDA	focal plane deck assembly
FPSA	focal plane structure assembly
FS	forward shell
FSS	flight support system
FWH	flexible wire harness
GEA	gimbal electronics assembly
GG	gravity gradient
GGM	GG mode
GPC	general purpose computer
GSE	ground support equipment
GSFC	Goddard Space Flight Center
GSTDN	ground spaceflight tracking and data network
HGA	high-gain antenna
HLD	high-level discrete
HOSC	Huntsville Operations Support Center
HRS	high resolution spectrograph
HSP	high-speed photometer
HST	Edwin P. Hubble Space Telescope
HWL	hardware load

I&C	instrumentation and communication
ICAPC	increased capacity adaptive payload carrier
ICU	instrumentation control unit
IDB	internal data bus
IMU	inertial measurement unit
IOU	input/output unit
IPCU	interface power control unit
IR	infrared
JSC	Lyndon B. Johnson Space Center
KA	keep alive
kbps	kilo bits per second
KSC	Kennedy Space Center
LGA	low-gain antenna
LLD	low-level discrete
LMU	logical memory unit
LS	light shield
LMSC	Lockheed Missiles and Space Company
MA	multiaccess
Mbps	megabits per second
MCC	Mission Control Center
MCC-H	MCC - Houston
MCE	monitor and control electronics
MCU	mechanism control unit
MDB	multiplexed data bus
MET	mission elapsed time
MLD	manual locking device
MLI	multi-layer insulation
MMS	multi-mission modular spacecraft
MOD	Mission Operations Directorate
MR	main ring
MRA	main ring assembly
MSB	most significant bit
MSFC	Marshall Space Flight Center
MSS	magnetic sensing system
MT	magnetic torquer
MTE	magnetic torquer electronics
MTP	master timing pulse
MTS	magnetic torquing system
MU	memory unit
N.m	Newton meter
NASA	National Aeronautics and Space Administration
NASCOM	NASA communications
NGT	NASCOM ground terminal
nm	nanometer
NSSC-I	NASA Standard Spacecraft Computer, Model I



OA0	Orbiting Astronomical Society
OCE	optical control subsystem
OCS	optical control subsystem
OCSO	oven-controlled crystal oscillator
OLD	offload device
OPI	Orbiter payload interrogator
ORU	orbital replaceable unit
ORUC	ORU carrier
OSO	Orbiting Solar Observatory
OTA	optical telescope assembly
OV	orbital verification
P-E	Perkin-Elmer Corporation
PC	planetary camera
PCM	pulse-code modulation
PCS	pointing control subsystem
	pointing control system
PCU	power control unit
PDI	payload data interleaver
PDM	primary deployment mechanism
PDU	power distribution unit
PI	payload interrogator
PI/KUSP	PI/Ku-band signal processor
PIT	process interface table
PLBD	payload bay door
PLR	payload recorder
PM	primary mirror
PMA	primary mirror assembly
PMB	primary mirror baffle
PMT	photomultiplier tube
PMU	physical memory unit
PN	pseudo-random noise
POCC	Payload Operations Control Center
PRCS	primary reaction control system
PRI	primary
PRIPL	unregulated Orbiter power
PRLA	payload retention latch assembly
PROM	programmable read-only memory
PSEA	pointing and safe-mode electronics assembly
psi	pounds per square inch
psia	pounds per square inch absolute
PSP	payload signal processor
PSP/PI	PSP/payload interrogator
QD	quick disconnect

RBM	radial bay module
RED	redundant
RF	radio frequency
RFI	radio frequency interface
RGA	rate gyro assembly
RGAI	RGA interface
RIG	rate integrating gyro
RIU	remote interface unit
RMGA	retrieval mode gyro assembly
RM	remote module
RMS	remote manipulator system
ROM	read-only memory
RPA	reaction plate assembly
RSOC	Rockwell Shuttle Operations Company
RSU	rate sensor unit
RTC	real-time command
RWA	reaction wheel assembly
SA	solar array
SAD	SA drive
SADA	SA drive adapter
SADE	SA drive electronics
SADM	SA drive mechanism
SD	science data or scientific data
SDM	secondary deployment mechanism
SI	scientific instrument
SIC&DH	scientific instrument control and data handling
SIP	standard interface panel
SIPE	scientific instrument protective enclosure
SISS	SI support structure
S/M	safe mode
SM	secondary mirror
SMA	secondary mirror assembly
SMB	secondary mirror baffle
SMC	safemode computer
SMCH	standard mixed cargo harness
SMSA	secondary mirror subassembly
SM4	safe-mode utility
SOC	state-of-charge
SPA	solar panel assembly
SPC	stored program command
SPG	single-point ground
SQPSK	staggered quadriphased, shift-keyed
SS	safing system
SSA	S-band single-access
SSC	Science Support Center
SSE	space support equipment
SSM	support systems module
SSM-ES	SSM equipment shelf
SSP	standard switch panel
SSS	star selector servo
STACC	standard telemetry and command components

STDN	space flight tracking and data network
STINT	standard interface
STOCC	Space Telescope Operations Control Center
STS	Space Transportation System
STSCI	Space Telescope Science Institute
TAG	two-axis gimbal
TBD	to be determined
TCE	thermal control electronics
TCS	thermal control subsystem
TCXO	temperature controlled crystal oscillator
TDRS	tracking and data relay satellite
TDRSS	TDRS system
TFC	TLM format control
TIM	timing interface module
TLM	telemetry
TRI	tape recorder interface
TTL	transistor-to-transistor logic
UDM	umbilical disconnect mechanism
ULE	ultralow expansion
URM	umbilical retraction mechanism
UV	ultraviolet
VATA	Vehicle Assembly and Test Area
VCO	voltage controlled oscillator
VSS	vehicle support software
VSWR	voltage standing wave radio
WF/PC	wide field/planetary camera
WFC	wide field camera
WSGT	White Sands Ground Terminal

SHUTTLE FLIGHTS AS OF DECEMBER 1993

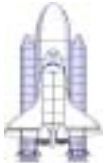
58 TOTAL FLIGHTS OF THE SHUTTLE SYSTEM -- 33 SINCE RETURN TO FLIGHT

																																																																													
																																																																													
<table border="1" style="width: 100%; border-collapse: collapse;"> <tr><td style="text-align: center;">STS-58</td></tr> <tr><td style="text-align: center;">10/18/93 - 11/01/93</td></tr> <tr><td style="text-align: center;">STS-55</td></tr> <tr><td style="text-align: center;">04/26/93 - 05/06/93</td></tr> <tr><td style="text-align: center;">STS-52</td></tr> <tr><td style="text-align: center;">10/22/92 - 11/01/92</td></tr> <tr><td style="text-align: center;">STS-50</td></tr> <tr><td style="text-align: center;">06/25/92 - 07/09/92</td></tr> <tr><td style="text-align: center;">STS-40</td></tr> <tr><td style="text-align: center;">06/05/91 - 06/14/91</td></tr> </table>		STS-58	10/18/93 - 11/01/93	STS-55	04/26/93 - 05/06/93	STS-52	10/22/92 - 11/01/92	STS-50	06/25/92 - 07/09/92	STS-40	06/05/91 - 06/14/91			<table border="1" style="width: 100%; border-collapse: collapse;"> <tr><td style="text-align: center;">STS-51</td></tr> <tr><td style="text-align: center;">09/12/93 - 09/22/93</td></tr> <tr><td style="text-align: center;">STS-56</td></tr> <tr><td style="text-align: center;">04/08/83 - 04/17/93</td></tr> <tr><td style="text-align: center;">STS-53</td></tr> <tr><td style="text-align: center;">12/02/92 - 12/09/92</td></tr> <tr><td style="text-align: center;">STS-42</td></tr> <tr><td style="text-align: center;">01/22/92 - 01/30/92</td></tr> <tr><td style="text-align: center;">STS-48</td></tr> <tr><td style="text-align: center;">09/12/91 - 09/18/91</td></tr> <tr><td style="text-align: center;">STS-39</td></tr> <tr><td style="text-align: center;">04/28/91 - 05/06/91</td></tr> <tr><td style="text-align: center;">STS-41</td></tr> <tr><td style="text-align: center;">10/06/90 - 10/10/90</td></tr> <tr><td style="text-align: center;">STS-31</td></tr> <tr><td style="text-align: center;">04/24/90 - 04/29/90</td></tr> <tr><td style="text-align: center;">STS-33</td></tr> <tr><td style="text-align: center;">11/22/89 - 11/27/89</td></tr> <tr><td style="text-align: center;">STS-29</td></tr> <tr><td style="text-align: center;">03/13/89 - 03/18/89</td></tr> <tr><td style="text-align: center;">STS-26</td></tr> <tr><td style="text-align: center;">09/29/88 - 10/03/88</td></tr> <tr><td style="text-align: center;">STS-51-I</td></tr> <tr><td style="text-align: center;">08/27/85 - 09/03/85</td></tr> <tr><td style="text-align: center;">STS-51G</td></tr> <tr><td style="text-align: center;">06/17/85 - 06/24/85</td></tr> <tr><td style="text-align: center;">STS-51D</td></tr> <tr><td style="text-align: center;">04/12/85 - 04/19/85</td></tr> <tr><td style="text-align: center;">STS-51C</td></tr> <tr><td style="text-align: center;">01/24/85 - 01/27/85</td></tr> <tr><td style="text-align: center;">STS-51A</td></tr> <tr><td style="text-align: center;">11/08/84 - 11/16/84</td></tr> <tr><td style="text-align: center;">STS-41D</td></tr> <tr><td style="text-align: center;">08/30/84 - 09/05/84</td></tr> </table>		STS-51	09/12/93 - 09/22/93	STS-56	04/08/83 - 04/17/93	STS-53	12/02/92 - 12/09/92	STS-42	01/22/92 - 01/30/92	STS-48	09/12/91 - 09/18/91	STS-39	04/28/91 - 05/06/91	STS-41	10/06/90 - 10/10/90	STS-31	04/24/90 - 04/29/90	STS-33	11/22/89 - 11/27/89	STS-29	03/13/89 - 03/18/89	STS-26	09/29/88 - 10/03/88	STS-51-I	08/27/85 - 09/03/85	STS-51G	06/17/85 - 06/24/85	STS-51D	04/12/85 - 04/19/85	STS-51C	01/24/85 - 01/27/85	STS-51A	11/08/84 - 11/16/84	STS-41D	08/30/84 - 09/05/84			<table border="1" style="width: 100%; border-collapse: collapse;"> <tr><td style="text-align: center;">STS-46</td></tr> <tr><td style="text-align: center;">07/31/92 - 08/08/92</td></tr> <tr><td style="text-align: center;">STS-45</td></tr> <tr><td style="text-align: center;">03/24/92 - 04/02/92</td></tr> <tr><td style="text-align: center;">STS-44</td></tr> <tr><td style="text-align: center;">11/24/91 - 12/01/91</td></tr> <tr><td style="text-align: center;">STS-43</td></tr> <tr><td style="text-align: center;">08/02/91 - 08/11/91</td></tr> <tr><td style="text-align: center;">STS-37</td></tr> <tr><td style="text-align: center;">04/05/91 - 04/11/91</td></tr> <tr><td style="text-align: center;">STS-38</td></tr> <tr><td style="text-align: center;">11/15/90 - 11/20/90</td></tr> <tr><td style="text-align: center;">STS-36</td></tr> <tr><td style="text-align: center;">02/28/90 - 03/04/90</td></tr> <tr><td style="text-align: center;">STS-34</td></tr> <tr><td style="text-align: center;">10/18/89 - 10/23/89</td></tr> <tr><td style="text-align: center;">STS-30</td></tr> <tr><td style="text-align: center;">05/04/89 - 05/08/89</td></tr> <tr><td style="text-align: center;">STS-27</td></tr> <tr><td style="text-align: center;">12/02/88 - 12/06/88</td></tr> <tr><td style="text-align: center;">STS-61B</td></tr> <tr><td style="text-align: center;">11/26/85 - 12/03/85</td></tr> <tr><td style="text-align: center;">STS-51J</td></tr> <tr><td style="text-align: center;">10/03/85 - 10/07/85</td></tr> </table>		STS-46	07/31/92 - 08/08/92	STS-45	03/24/92 - 04/02/92	STS-44	11/24/91 - 12/01/91	STS-43	08/02/91 - 08/11/91	STS-37	04/05/91 - 04/11/91	STS-38	11/15/90 - 11/20/90	STS-36	02/28/90 - 03/04/90	STS-34	10/18/89 - 10/23/89	STS-30	05/04/89 - 05/08/89	STS-27	12/02/88 - 12/06/88	STS-61B	11/26/85 - 12/03/85	STS-51J	10/03/85 - 10/07/85
STS-58																																																																													
10/18/93 - 11/01/93																																																																													
STS-55																																																																													
04/26/93 - 05/06/93																																																																													
STS-52																																																																													
10/22/92 - 11/01/92																																																																													
STS-50																																																																													
06/25/92 - 07/09/92																																																																													
STS-40																																																																													
06/05/91 - 06/14/91																																																																													
STS-51																																																																													
09/12/93 - 09/22/93																																																																													
STS-56																																																																													
04/08/83 - 04/17/93																																																																													
STS-53																																																																													
12/02/92 - 12/09/92																																																																													
STS-42																																																																													
01/22/92 - 01/30/92																																																																													
STS-48																																																																													
09/12/91 - 09/18/91																																																																													
STS-39																																																																													
04/28/91 - 05/06/91																																																																													
STS-41																																																																													
10/06/90 - 10/10/90																																																																													
STS-31																																																																													
04/24/90 - 04/29/90																																																																													
STS-33																																																																													
11/22/89 - 11/27/89																																																																													
STS-29																																																																													
03/13/89 - 03/18/89																																																																													
STS-26																																																																													
09/29/88 - 10/03/88																																																																													
STS-51-I																																																																													
08/27/85 - 09/03/85																																																																													
STS-51G																																																																													
06/17/85 - 06/24/85																																																																													
STS-51D																																																																													
04/12/85 - 04/19/85																																																																													
STS-51C																																																																													
01/24/85 - 01/27/85																																																																													
STS-51A																																																																													
11/08/84 - 11/16/84																																																																													
STS-41D																																																																													
08/30/84 - 09/05/84																																																																													
STS-46																																																																													
07/31/92 - 08/08/92																																																																													
STS-45																																																																													
03/24/92 - 04/02/92																																																																													
STS-44																																																																													
11/24/91 - 12/01/91																																																																													
STS-43																																																																													
08/02/91 - 08/11/91																																																																													
STS-37																																																																													
04/05/91 - 04/11/91																																																																													
STS-38																																																																													
11/15/90 - 11/20/90																																																																													
STS-36																																																																													
02/28/90 - 03/04/90																																																																													
STS-34																																																																													
10/18/89 - 10/23/89																																																																													
STS-30																																																																													
05/04/89 - 05/08/89																																																																													
STS-27																																																																													
12/02/88 - 12/06/88																																																																													
STS-61B																																																																													
11/26/85 - 12/03/85																																																																													
STS-51J																																																																													
10/03/85 - 10/07/85																																																																													
<table border="1" style="width: 100%; border-collapse: collapse;"> <tr><td style="text-align: center;">STS-35</td></tr> <tr><td style="text-align: center;">12/02/90 - 12/10/90</td></tr> <tr><td style="text-align: center;">STS-32</td></tr> <tr><td style="text-align: center;">01/09/90 - 01/20/90</td></tr> <tr><td style="text-align: center;">STS-28</td></tr> <tr><td style="text-align: center;">08/08/89 - 08/13/89</td></tr> <tr><td style="text-align: center;">STS-61C</td></tr> <tr><td style="text-align: center;">01/12/86 - 01/18/86</td></tr> <tr><td style="text-align: center;">STS-9</td></tr> <tr><td style="text-align: center;">11/28/83 - 12/08/83</td></tr> <tr><td style="text-align: center;">STS-5</td></tr> <tr><td style="text-align: center;">11/11/82 - 11/16/82</td></tr> <tr><td style="text-align: center;">STS-4</td></tr> <tr><td style="text-align: center;">06/27/82 - 07/04/82</td></tr> <tr><td style="text-align: center;">STS-3</td></tr> <tr><td style="text-align: center;">03/22/82 - 03/30/82</td></tr> <tr><td style="text-align: center;">STS-2</td></tr> <tr><td style="text-align: center;">11/12/81 - 11/14/81</td></tr> <tr><td style="text-align: center;">STS-1</td></tr> <tr><td style="text-align: center;">04/12/81 - 04/14/81</td></tr> </table>		STS-35	12/02/90 - 12/10/90	STS-32	01/09/90 - 01/20/90	STS-28	08/08/89 - 08/13/89	STS-61C	01/12/86 - 01/18/86	STS-9	11/28/83 - 12/08/83	STS-5	11/11/82 - 11/16/82	STS-4	06/27/82 - 07/04/82	STS-3	03/22/82 - 03/30/82	STS-2	11/12/81 - 11/14/81	STS-1	04/12/81 - 04/14/81	<table border="1" style="width: 100%; border-collapse: collapse;"> <tr><td style="text-align: center;">STS-51L</td></tr> <tr><td style="text-align: center;">01/28/86</td></tr> <tr><td style="text-align: center;">STS-61A</td></tr> <tr><td style="text-align: center;">10/30/85 - 11/06/85</td></tr> <tr><td style="text-align: center;">STS-51F</td></tr> <tr><td style="text-align: center;">07/29/85 - 08/06/85</td></tr> <tr><td style="text-align: center;">STS-51B</td></tr> <tr><td style="text-align: center;">04/29/85 - 05/06/85</td></tr> <tr><td style="text-align: center;">STS-41G</td></tr> <tr><td style="text-align: center;">10/05/84 - 10/13/84</td></tr> <tr><td style="text-align: center;">STS-41C</td></tr> <tr><td style="text-align: center;">04/06/84 - 04/13/84</td></tr> <tr><td style="text-align: center;">STS-41B</td></tr> <tr><td style="text-align: center;">02/03/84 - 02/11/84</td></tr> <tr><td style="text-align: center;">STS-8</td></tr> <tr><td style="text-align: center;">08/30/83 - 09/05/83</td></tr> <tr><td style="text-align: center;">STS-7</td></tr> <tr><td style="text-align: center;">06/18/83 - 06/24/83</td></tr> <tr><td style="text-align: center;">STS-6</td></tr> <tr><td style="text-align: center;">04/04/83 - 04/09/83</td></tr> </table>		STS-51L	01/28/86	STS-61A	10/30/85 - 11/06/85	STS-51F	07/29/85 - 08/06/85	STS-51B	04/29/85 - 05/06/85	STS-41G	10/05/84 - 10/13/84	STS-41C	04/06/84 - 04/13/84	STS-41B	02/03/84 - 02/11/84	STS-8	08/30/83 - 09/05/83	STS-7	06/18/83 - 06/24/83	STS-6	04/04/83 - 04/09/83	<table border="1" style="width: 100%; border-collapse: collapse;"> <tr><td style="text-align: center;">STS-47</td></tr> <tr><td style="text-align: center;">09/12/92 - 09/20/92</td></tr> <tr><td style="text-align: center;">STS-49</td></tr> <tr><td style="text-align: center;">05/07/92 - 05/16/92</td></tr> <tr><td style="text-align: center;">STS-57</td></tr> <tr><td style="text-align: center;">06/21/93 - 07/01/93</td></tr> <tr><td style="text-align: center;">STS-54</td></tr> <tr><td style="text-align: center;">01/13/93 - 01/19/93</td></tr> </table>		STS-47	09/12/92 - 09/20/92	STS-49	05/07/92 - 05/16/92	STS-57	06/21/93 - 07/01/93	STS-54	01/13/93 - 01/19/93																								
STS-35																																																																													
12/02/90 - 12/10/90																																																																													
STS-32																																																																													
01/09/90 - 01/20/90																																																																													
STS-28																																																																													
08/08/89 - 08/13/89																																																																													
STS-61C																																																																													
01/12/86 - 01/18/86																																																																													
STS-9																																																																													
11/28/83 - 12/08/83																																																																													
STS-5																																																																													
11/11/82 - 11/16/82																																																																													
STS-4																																																																													
06/27/82 - 07/04/82																																																																													
STS-3																																																																													
03/22/82 - 03/30/82																																																																													
STS-2																																																																													
11/12/81 - 11/14/81																																																																													
STS-1																																																																													
04/12/81 - 04/14/81																																																																													
STS-51L																																																																													
01/28/86																																																																													
STS-61A																																																																													
10/30/85 - 11/06/85																																																																													
STS-51F																																																																													
07/29/85 - 08/06/85																																																																													
STS-51B																																																																													
04/29/85 - 05/06/85																																																																													
STS-41G																																																																													
10/05/84 - 10/13/84																																																																													
STS-41C																																																																													
04/06/84 - 04/13/84																																																																													
STS-41B																																																																													
02/03/84 - 02/11/84																																																																													
STS-8																																																																													
08/30/83 - 09/05/83																																																																													
STS-7																																																																													
06/18/83 - 06/24/83																																																																													
STS-6																																																																													
04/04/83 - 04/09/83																																																																													
STS-47																																																																													
09/12/92 - 09/20/92																																																																													
STS-49																																																																													
05/07/92 - 05/16/92																																																																													
STS-57																																																																													
06/21/93 - 07/01/93																																																																													
STS-54																																																																													
01/13/93 - 01/19/93																																																																													
<table border="1" style="width: 100%; border-collapse: collapse;"> <tr><td style="text-align: center;">OV-102</td></tr> <tr><td style="text-align: center;">Columbia</td></tr> <tr><td style="text-align: center;">(15 flights)</td></tr> </table>		OV-102	Columbia	(15 flights)	<table border="1" style="width: 100%; border-collapse: collapse;"> <tr><td style="text-align: center;">OV-099</td></tr> <tr><td style="text-align: center;">Challenger</td></tr> <tr><td style="text-align: center;">(10 flights)</td></tr> </table>		OV-099	Challenger	(10 flights)	<table border="1" style="width: 100%; border-collapse: collapse;"> <tr><td style="text-align: center;">OV-103</td></tr> <tr><td style="text-align: center;">Discovery</td></tr> <tr><td style="text-align: center;">(17 flights)</td></tr> </table>		OV-103	Discovery	(17 flights)	<table border="1" style="width: 100%; border-collapse: collapse;"> <tr><td style="text-align: center;">OV-104</td></tr> <tr><td style="text-align: center;">Atlantis</td></tr> <tr><td style="text-align: center;">(12 flights)</td></tr> </table>		OV-104	Atlantis	(12 flights)	<table border="1" style="width: 100%; border-collapse: collapse;"> <tr><td style="text-align: center;">OV-105</td></tr> <tr><td style="text-align: center;">Endeavour</td></tr> <tr><td style="text-align: center;">(4 flights)</td></tr> </table>		OV-105	Endeavour	(4 flights)																																																					
OV-102																																																																													
Columbia																																																																													
(15 flights)																																																																													
OV-099																																																																													
Challenger																																																																													
(10 flights)																																																																													
OV-103																																																																													
Discovery																																																																													
(17 flights)																																																																													
OV-104																																																																													
Atlantis																																																																													
(12 flights)																																																																													
OV-105																																																																													
Endeavour																																																																													
(4 flights)																																																																													